

PacT Series

MasterPacT MTZ IEC Circuit Breakers With MicroLogic Active Control Unit

End-User Maintenance Procedures

PacT Series offers world-class breakers and switches

DOCA0306EN-00
03/2024



Legal Information

The information provided in this document contains general descriptions, technical characteristics and/or recommendations related to products/solutions.

This document is not intended as a substitute for a detailed study or operational and site-specific development or schematic plan. It is not to be used for determining suitability or reliability of the products/solutions for specific user applications. It is the duty of any such user to perform or have any professional expert of its choice (integrator, specifier or the like) perform the appropriate and comprehensive risk analysis, evaluation and testing of the products/solutions with respect to the relevant specific application or use thereof.

The Schneider Electric brand and any trademarks of Schneider Electric SE and its subsidiaries referred to in this document are the property of Schneider Electric SE or its subsidiaries. All other brands may be trademarks of their respective owner.

This document and its content are protected under applicable copyright laws and provided for informative use only. No part of this document may be reproduced or transmitted in any form or by any means (electronic, mechanical, photocopying, recording, or otherwise), for any purpose, without the prior written permission of Schneider Electric.

Schneider Electric does not grant any right or license for commercial use of the document or its content, except for a non-exclusive and personal license to consult it on an "as is" basis.

Schneider Electric reserves the right to make changes or updates with respect to or in the content of this document or the format thereof, at any time without notice.

To the extent permitted by applicable law, no responsibility or liability is assumed by Schneider Electric and its subsidiaries for any errors or omissions in the informational content of this document, as well as any non-intended use or misuse of the content thereof.

Table of Contents

Safety Information.....	5
About the Book.....	6
Introduction	9
PacT Series Master Range.....	10
Introduction.....	11
Preventive Maintenance Frequency	12
Process of Preventive Maintenance	16
Maintenance Schedule	17
Schneider Electric Green Premium™ Ecolabel	18
Routine End-User Maintenance Procedures	21
Device NII_ZA_1: Check the General Condition of the Device	22
Mechanism NII_ZA_1: Operate the Device Manually and Electrically.....	28
Mechanism NII_ZA_2: Charge the Device Electrically with MCH Gear Motor.....	34
Mechanism NII_ZA_3: Check the Complete Closing of Device Poles.....	38
Auxiliaries NII_ZA_1: Check Auxiliary Wiring and Insulation.....	40
Control Unit NII_ZA_1: Check Device Tripping and Operation of SDE Fault-Trip Indication Contacts	43
Control Unit NII_ZA_2: Check Ground-Fault Protection Function (MicroLogic Active 6.0)	48
Control Unit NII_ZA_3: Check Operation of Energy Reduction Maintenance Settings (ERMS).....	51
Device Locking NII_ZA_1: Operate Device Keylocks.....	55
Device Locking NII_ZA_2: Operate Device Padlocks.....	58
Chassis NII_ZA_1: Check Device Racking Operation	61
Chassis NII_ZA_2: Check IBPO Racking Interlock (MasterPacT MTZ2/ MTZ3)	66
Chassis Locking NII_ZA_1: Operate Chassis Keylocking System.....	68
Chassis Locking NII_ZA_2: Operate Chassis Padlocking System.....	72
Mechanical Interlocking NII_ZA_1: Operate Interlocking Systems	75
Intermediate End-User Maintenance Procedures	78
Mechanism NIII_ZA_1: Check the MCH Gear Motor Charging Time at 0.85 Un.....	79
Mechanism NIII_ZA_2: Check the General Condition of the Mechanism	82
Mechanism NIII_ZA_3: Check the Number of Device Operating Cycles	88
Breaking Unit NIII_ZA_1: Check the Condition of the Breaking Unit	90
Breaking Unit NIII_ZA_2: Check Mounting of Arc Chutes and Filter Cleanliness	97
Auxiliaries NIII_ZA_1: Check Operation of Indication Contacts (OF, PF).....	99
Auxiliaries NIII_ZA_2: Check Closing Operation with XF Closing Voltage Release at 0.85 Un	103
Auxiliaries NIII_ZA_3: Check Opening Operation with MX Opening Voltage Release at 0.7 Un.....	106

Auxiliaries NIII_ZA_4: Check Closing and Opening Operations with MN Undervoltage Release	109
Auxiliaries NIII_ZA_5: Check Time Delay of MNR Delayed Undervoltage Release	113
Control Unit NIII_ZA_3: Save Protection Settings, Reports, and Event Logs With EcoStruxure Power Commission Software	116
Control Unit NIII_ZA_4: Check Overcurrent Protection	120
Chassis NIII_ZA_1: Check Operation of CD, CT, CE Position Contacts and EF Auxiliary Contacts	127
Chassis NIII_ZA_2: Check Operation of Safety Shutters	135
Chassis NIII_ZA_3: Clean Chassis and Check Presence of Grease on Chassis	142
Chassis NIII_ZA_4: Check Disconnecting Contact Clusters	146
Power Connections NIII_ZA_1: Check Connection System	149
MasterPacT MTZ Troubleshooting	155
Introduction to Troubleshooting	156
Troubleshooting: Chassis Operation	158
Troubleshooting: Unexpected Tripping	159
Troubleshooting: Mechanical Control Operations	160
Troubleshooting: Electrical Control Operations	162

Safety Information

Important Information

Read these instructions carefully, and look at the equipment to become familiar with the device before trying to install, operate, service, or maintain it. The following special messages may appear throughout this documentation or on the equipment to warn of potential hazards or to call attention to information that clarifies or simplifies a procedure.



The addition of this symbol to a “Danger” or “Warning” safety label indicates that an electrical hazard exists which will result in personal injury if the instructions are not followed.



This is the safety alert symbol. It is used to alert you to potential personal injury hazards. Obey all safety messages that follow this symbol to avoid possible injury or death.

DANGER

DANGER indicates a hazardous situation which, if not avoided, **will result in** death or serious injury.

WARNING

WARNING indicates a hazardous situation which, if not avoided, **could result in** death or serious injury.

CAUTION

CAUTION indicates a hazardous situation which, if not avoided, **could result in** minor or moderate injury.

NOTICE

NOTICE is used to address practices not related to physical injury.

Please Note

Electrical equipment should be installed, operated, serviced, and maintained only by qualified personnel. No responsibility is assumed by Schneider Electric for any consequences arising out of the use of this material.

A qualified person is one who has skills and knowledge related to the construction and operation of electrical equipment and its installation, and has received safety training to recognize and avoid the hazards involved.

About the Book

Document Scope

The aim of this document is to provide trained and qualified maintenance personnel with the technical information needed to perform Routine and Intermediate end-user preventive maintenance on the following devices:

- MasterPacT™ MTZ1 IEC circuit breakers with MicroLogic™ Active control unit
- MasterPacT™ MTZ2/MTZ3 IEC circuit breakers with MicroLogic™ Active control unit

For general information about Schneider Electric maintenance policies and expertise and tools, contact your Schneider Electric representative.

Validity Note

This document applies to MasterPacT MTZ1/MTZ2/MTZ3 IEC circuit breakers with MicroLogic Active control unit.

Online Information

The information contained in this guide is likely to be updated at any time. Schneider Electric strongly recommends that you have the most recent and up-to-date version available on www.se.com/ww/en/download.

The technical characteristics of the devices described in this guide also appear online. To access the information online, go to the Schneider Electric home page at www.se.com.

Convention

In this document, the term *MasterPacT MTZ device* covers MasterPacT MTZ circuit breakers with MicroLogic Active control unit.

Related Documents

Title of Documentation	Reference Number
<i>MasterPacT MTZ Catalog</i>	LVPED225010EN
<i>MasterPacT MTZ Catalog numbers and spare parts</i>	COM-POWER-LVMKT224EN
<i>MasterPacT MTZ IEC Circuit Breakers with MicroLogic Active Control Unit - Maintenance Guide</i>	DOCA0305EN
<i>MasterPacT MTZ1 IEC Circuit Breakers with MicroLogic Active Control Unit - User Guide</i>	DOCA0284EN
<i>MasterPacT MTZ2/MTZ3 IEC Circuit Breakers with MicroLogic Active Control Unit - User Guide</i>	DOCA0285EN
<i>MasterPacT MTZ - MicroLogic Active Control Unit - User Guide</i>	DOCA0265EN
<i>MasterPacT MTZ1 - Fixed IEC Circuit Breaker with MicroLogic Active Control Unit - Instruction Sheet</i>	PKR4242702
<i>MasterPacT MTZ1 - Drawout IEC Circuit Breaker with MicroLogic Active Control Unit - Instruction Sheet</i>	PKR4242802

Title of Documentation	Reference Number
<i>MasterPacT MTZ2/MTZ3 - Fixed IEC Circuit Breaker with MicroLogic Active Control Unit - Instruction Sheet</i>	PKR4242002
<i>MasterPacT MTZ2/MTZ3 - Drawout IEC Circuit Breaker with MicroLogic Active Control Unit - Instruction Sheet</i>	PKR4243502
<i>MasterPacT MTZ1 3P/4P - Front Cover - Instruction Sheet</i>	NVE56771
<i>MasterPacT MTZ2 3P/4P - Front Cover - Instruction Sheet</i>	NVE16117
<i>MasterPacT MTZ1/MTZ2/MTZ3 - MicroLogic Transparent Cover - Instruction Sheet</i>	NVE16151
<i>MicroLogic Active - Spare Battery - Instruction Sheet</i>	PKR4244002
<i>MasterPacT MTZ1 - CDM Operation Counter - Instruction Sheet</i>	NVE35516
<i>MasterPacT MTZ2/MTZ3 - CDM Operation Counter - Instruction Sheet</i>	NVE35485
<i>MasterPacT MTZ1/MTZ2/MTZ3 - Auxiliary Terminals - Instruction Sheet</i>	NVE35463
<i>MasterPacT MTZ1/MTZ2/MTZ3 - MN-MX-XF Voltage Releases - Instruction Sheet</i>	NVE40749
<i>MasterPacT MTZ1 - MCH Gear Motor - Instruction Sheet</i>	NVE35514
<i>MasterPacT MTZ2/MTZ3 - MCH Gear Motor - Instruction Sheet</i>	NVE35483
<i>MasterPacT MTZ1 - Arc Chute - Instruction Sheet</i>	NVE35511
<i>MasterPacT MTZ2/MTZ3 - Arc Chute - Instruction Sheet</i>	NVE35479
<i>MasterPacT MTZ2/MTZ3 - SDE2 Fault-Trip Indication Contact / RES Remote Reset - Instruction Sheet</i>	NVE35503
<i>MasterPacT MTZ1 - VBP Lockable Pushbutton Cover - Instruction Sheet</i>	NVE56769
<i>MasterPacT MTZ2/MTZ3 - VBP Lockable Pushbutton Cover - Instruction Sheet</i>	NVE16147
<i>MasterPacT MTZ1 - VCPO OFF-Position Locking and BPFE Support - Instruction Sheet</i>	NVE56770
<i>MasterPacT MTZ2/MTZ3 - VCPO OFF-Position Locking and BPFE Support - Instruction Sheet</i>	NVE16146
<i>MasterPacT MTZ1/MTZ2/MTZ3 - Position Contacts (Connected / Disconnected / Test) - Instruction Sheet</i>	NVE16135
<i>MasterPacT MTZ2/MTZ3 - EF Combined Connected/Closed Contact - Instruction Sheet</i>	NVE35482
<i>MasterPacT MTZ1 - Safety Shutters - Instruction Sheet</i>	NVE35509
<i>MasterPacT MTZ2/MTZ3 - Safety Shutters - Instruction Sheet</i>	NVE35476
<i>MasterPacT MTZ2/MTZ3 - VIVC Front Face Shutter Position Indication and Locking - Instruction Sheet</i>	NVE35478
<i>MasterPacT MTZ1 - VSPD Disconnected Position Locking - Instruction Sheet</i>	NVE56768
<i>MasterPacT MTZ2/MTZ3 - VSPD Disconnected Position Locking - Instruction Sheet</i>	NVE16142
<i>MasterPacT MTZ1 - Mechanical Interlocking for Source Changeover (2 Sources / Cable) - Instruction Sheet</i>	NVE35522
<i>MasterPacT MTZ1 - Mechanical Interlocking for Source Changeover (2 Sources / Rods) - Instruction Sheet</i>	NVE35523
<i>MasterPacT MTZ1 - IPA Cable-Type Door Interlock - Instruction Sheet</i>	NVE35521
<i>MasterPacT MTZ2/MTZ3 - IPA Cable-Type Door Interlock - Instruction Sheet</i>	NVE35495
<i>MasterPacT MTZ2/MTZ3 - Mechanical Interlocking for Source Changeover (2 Sources / Cable) - Instruction Sheet</i>	NVE35496
<i>MasterPacT MTZ2/MTZ3 - Mechanical Interlocking for Source Changeover (2 Sources / Rods) - Instruction Sheet</i>	NVE35497
<i>MasterPacT MTZ2/MTZ3 - Mechanical Interlocking for 3 Sources - Instruction Sheet</i>	NVE35498

Title of Documentation	Reference Number
<i>MasterPacT MTZ2/MTZ3 - Mechanical Interlocking for 2 Sources and 1 Replacement - Instruction Sheet</i>	NVE35499
<i>MasterPacT MTZ2/MTZ3 - Mechanical Interlocking for 2 Sources and 1 Coupling - Instruction Sheet</i>	NVE35500
<i>MasterPacT MTZ1/MTZ2/MTZ3 - Set of 2 Cables for Interlocking 2.5 m (8.2 ft) - Instruction Sheet</i>	NVE61729
<i>MasterPacT MTZ1/MTZ2/MTZ3 - Set of 2 Rods for Interlocking - Instruction Sheet</i>	NVE61744
<i>MasterPacT MTZ1 - OF ON/OFF Indication Contacts - Instruction Sheet</i>	NVE35513
<i>MasterPacT MTZ2/MTZ3 - OF ON/OFF Indication Contacts - Instruction Sheet</i>	NVE35481
<i>MasterPacT MTZ1/MTZ2/MTZ3 - PF Ready-To-Close Contact - Instruction Sheet</i>	NVE35466
<i>MasterPacT MTZ1 - Connectors - Instruction Sheet</i>	NVE35507
<i>MasterPacT MTZ2/MTZ3 - Connectors - Instruction Sheet</i>	NVE35472

Information on Non-Inclusive or Insensitive Terminology

As a responsible, inclusive company, Schneider Electric is constantly updating its communications and products that contain non-inclusive or insensitive terminology. However, despite these efforts, our content may still contain terms that are deemed inappropriate by some customers.

Trademarks

QR Code is a registered trademark of DENSO WAVE INCORPORATED in Japan and other countries.

Introduction

What's in This Part

PacT Series Master Range	10
Introduction.....	11
Preventive Maintenance Frequency.....	12
Process of Preventive Maintenance	16
Maintenance Schedule	17
Schneider Electric Green Premium™ Ecolabel	18

PacT Series Master Range

Future-proof your installation with Schneider Electric's low-voltage and medium-voltage PacT Series. Built on legendary Schneider Electric innovation, the PacT Series comprises world-class circuit breakers, switches, residual current devices and fuses, for all standard and specific applications. Experience robust performance with PacT Series within the EcoStruxure-ready switchgear, from 16 to 6300 A in low-voltage and up to 40.5 kV in medium-voltage.

Introduction

Introduction

Preventive maintenance tasks on MasterPacT MTZ circuit breakers with MicroLogic Active control unit are to be carried out following the Schneider Electric maintenance strategy.

Preventive maintenance tasks are organized into three programs depending on complexity and maintenance frequency, page 12:

- Routine end-user maintenance
- Intermediate end-user maintenance
- Manufacturer maintenance

Refer to *MasterPacT MTZ IEC Circuit Breakers with MicroLogic Active Control Unit - Maintenance Guide* for the detailed Schneider Electric maintenance strategy.

Instruction Sheets

When a corrective action in a maintenance procedure references an instruction sheet, refer to the Related documents section at the top of the procedure to find the relevant instruction sheet for the product.

Illustrations

The pictures and drawings in this document are for illustration only.

Tools

Performing the procedures of the maintenance program requires the following:

- A standard toolbox with electrical tools and equipment for an electrician.
- Specific tools, detailed in the maintenance procedures.

Preventive Maintenance Frequency

Preventive Maintenance Safety Instructions

Maintenance recommendations for each device are intended to maintain the equipment or subassemblies in a satisfactory operational state for their useful service life.

Preventive maintenance schedule is calculated by the MicroLogic Active control unit from:

- The operating conditions of the MasterPacT MTZ device.
- The criticality of the user application.

The MicroLogic Active control unit generates an event to inform the user that manufacturer maintenance needs to be planned to conform to the preventive maintenance schedule.

⚠ WARNING

UNINTENDED EQUIPMENT OPERATION

Follow the recommendations for the maintenance given in the different chapters of this document, for each part of the device which is maintainable.

Failure to follow these instructions can result in death, serious injury, or equipment damage.

If the recommended maintenance plan is not done as required, the service life of electrical distribution equipment is reduced.

Maintenance Programs

The following table summarizes maintenance operations for the three preventive maintenance programs:

Maintenance program	Maintenance description	Performed by
Routine end-user maintenance	Visual inspection and functional testing, replacement of inoperative accessories.	<ul style="list-style-type: none"> • Trained and qualified end-user personnel • Trained and qualified maintenance services provider personnel • Schneider Electric Services representatives
Intermediate end-user maintenance	Routine end-user maintenance, plus operational servicing and subassembly tests.	<ul style="list-style-type: none"> • Trained and qualified maintenance services provider personnel • Schneider Electric Services representatives
Manufacturer maintenance	Intermediate end-user maintenance, plus diagnostics and part replacements by Schneider Electric Services.	Schneider Electric Services representatives

Favorable Environmental Conditions and Device Operating Conditions

Environmental conditions and device operating conditions are considered to be favorable **when all of the following conditions** are met:

Favorable environmental conditions and device operating conditions	
Temperature	Annual average ambient temperature outside the switchboard $T_a < 25\text{ °C}$ (77 °F) (IEC 61439-1). Device installed in an air-conditioned room or in a ventilated switchboard.
Percent load	< 50 % of I_n (daily process 8/24 h or continuous process 24/24 h)
Relative humidity	< 50 %
Corrosive atmosphere	Device installed in category 3C1 environment or in a closed room that creates favorable operating conditions (air is conditioned and purified).
Salt environment	None
Dust	Negligible. Device installed in a switchboard equipped with filters or a ventilated IP54 enclosure.
Vibration	None

Normal Environmental Conditions and Device Operating Conditions

Environmental conditions and device operating conditions are considered to be normal **when all of the following conditions** are met:

Normal environmental conditions and device operating conditions	
Temperature	Annual average ambient temperature outside the switchboard $T_a < 25\text{ °C}$ (77 °F) (IEC 61439-1)
Percent load	< 80 % of I_n (daily process 8/24 h or continuous process 24/24 h)
Harmonics	Harmonic current per phase < 30 % of I_n
Relative humidity	< 70 %
Corrosive atmosphere	Device installed in environment category 3C2 or 3C3 (IEC 60721-3-3)
Salt environment	No salt mist
Dust	Low level. Device installed in a switchboard equipped with filters or a ventilated IP54 enclosure.
Vibration	Permanent vibration < 0.2 g

Severe Environmental Conditions and Device Operating Conditions

Environmental conditions and device operating conditions are considered to be severe **if any of the following conditions** are present:

Severe environmental conditions and device operating conditions	
Temperature	Annual average ambient temperature outside the switchboard Ta between 35 °C (95 °F) and 45 °C (113 °F) (IEC 61439-1)
Percent load	> 80 % of In (daily process 8/24 h or continuous process 24/24 h)
Relative humidity	> 80 %
Corrosive atmosphere	Device installed in category 3C4 environment without any particular protection
Salt environment	Device installed less than 10 kilometers from the coast without any particular protection
Dust	High level. Device not installed inside an enclosure equipped with filters or a ventilated IP54 enclosure.
Vibration	Continuous vibrations between 0.2 g and 0.5 g

For example, severe environmental conditions and device operating conditions prevail in marine and wind power applications.

Criticality of User Application

The following table describes the three criticality levels of user application.

Criticality level	Description
Low	The loss of function will cause minimal curtailment of operations or may require minimal monetary investment to restore full operations. Normal contingency planning would cover the loss.
Moderate	The loss of function will have noticeable impact on the facility. It may have to suspend some operations briefly. Some monetary investments may be necessary to restore full operations. It may cause minor personal injury.
High	The loss of function will cause personal injury or substantial economic damage. Loss would not be disastrous, but the facility would have to suspend at least part of its operations immediately and temporarily. Reopening the facility would require significant monetary investments.

Recommended Frequency for the Routine End-User Maintenance Program

The following table indicates the recommended frequency to perform the Routine end-user maintenance program according to operating conditions and criticality of the user application.

Operating conditions	Criticality of user application		
	Low	Moderate	High
Favorable	2 years	2 years	2 years
Normal	1 year	1 year	1 year
Severe	1 year	1 year	1 year

Recommended Frequency for the Intermediate End-User Maintenance Program

The following table indicates the recommended frequency to perform the Intermediate end-user maintenance program according to operating conditions and criticality of the user application.

Operating conditions	Criticality of user application		
	Low	Moderate	High
Favorable	4 years	4 years	4 years
Normal	2 years	2 years	2 years
Severe	2 years	2 years	2 years

Recommended Frequency for the Manufacturer Maintenance Program

The following table indicates the recommended frequency to perform the Manufacturer maintenance program according to operating conditions and criticality of the user application.

Operating conditions	Criticality of user application		
	Low	Moderate	High
Favorable	6 years	5 years	4 years
Normal	5 years	4 years	3 years
Severe	4 years	3 years	2 years

A complete check-up is recommended when tripping occurs due to a short-time or instantaneous short-circuit.

Process of Preventive Maintenance

Process of Manufacturer Maintenance Program

The Manufacturer preventive maintenance includes the following stages:

Stage	Description
1	Take note of the notification (on MicroLogic Active HMI, EcoStruxure Power Device app, or EcoStruxure Power Commission software) that the Manufacturer maintenance program is required.
2	Schedule the Manufacturer maintenance program with your Schneider Electric Services representative.
3	The Schneider Electric Services representative performs the Manufacturer maintenance.

Maintenance Schedule

Overview

The MicroLogic Active control unit provides information to help with scheduling preventive maintenance operations.

It monitors maintenance programs performed and generates an event to indicate that Manufacturer maintenance is due.

Operating Principle

The MicroLogic Active control unit generates an event to indicate that Manufacturer maintenance is due.

Manufacturer maintenance schedule events are calculated from the assembly date of the circuit breaker.

Predefined Events

The maintenance schedule function generates the following events:

Code	Event	History	Severity
0x1482 (5250)	Sched. Manufact. maintenance within 3 months	Diagnostic	Medium

Recommended Actions

Code	Event	Recommended actions
0x1482 (5250)	Sched. Manufact. maintenance within 3 months	Plan to schedule the Manufacturer preventive maintenance program within three months. To plan, edit report and track maintenance intervention, you may use EcoStruxure Facility Expert app.

Schneider Electric Green Premium™ Ecolabel

Description

Green Premium is a label that allows you to develop and promote an environmental policy while preserving your business efficiency. This ecolabel is compliant with up-to-date environmental regulations.



Accessing Green Premium

Green Premium data on labeled products can be accessed online through any of the following ways:

- By navigating to the Green Premium page on the Schneider Electric website.
- By navigating to the product page on the mySchneider application on your smartphone

NOTE: To download and install the mySchneider app, scan the QR code on the front face of any Schneider Electric product and click the mySchneider link to go to your app store.

Checking Products Through the Schneider Electric Website

To check the environmental criteria of a product using a PC or smartphone, follow these steps:

Step	Action
1	On the Green Premium page, select Sustainability > For customers > Green Premium products .
2	Click Check your product and access environmental data .
3	On the page Check a product , manually enter the commercial reference or product range of the product to search for. NOTE: You can also select the Search a list of part numbers tab to send a file with a list of commercial references of products to search for.
4	To search for several products simultaneously, click Add product and then fill in the fields.
5	Click Check product(s) to generate a report of the environmental criteria available for the products with the entered commercial references.
6	A window named Green Premium Declaration appears. Click on I accept to access the product information.
7	The Check a product page is displayed with the list of documents for the selected products for each type of environmental data. Each document can be downloaded to your PC.

Checking Products Through the mySchneider App

To check the environmental criteria of a product using mySchneider app on your smartphone, follow these steps:

Step	Action
1	Open the mySchneider app.
2	In the search field at the top of the Product Catalog page: <ul style="list-style-type: none"> • Enter the commercial reference of the product to search for • or press the QR code icon in the search box  and scan the QR code on the front face of the product to search for.
3	When the page of the commercial reference searched for opens, scroll down and select Green Premium .
4	The Green Premium documents attached to the product are listed on the Green Premium page. Select the required document to refer or download it.

Environmental Criteria

The Green Premium ecolabel provides documentation on the following criteria about the environmental impact of the products:

- RoHS: Restriction of Hazardous Substances (RoHS) directive
 - For European Union
 - For China
- REACH: European Union Registration, Evaluation, Authorization, and Restriction of Chemicals regulation.
- Product Environmental Profile (PEP)
- End of Life Instructions (EoLI).

RoHS

Schneider Electric products are subject to RoHS requirements at a worldwide level, even for the many products that are not required to comply with the terms of the regulation. Compliance certificates are available for products that fulfill:

- The RoHS criteria defined by the European Union.
- The RoHS criteria defined by China.

REACH

Schneider Electric applies the strict REACH regulation on its products at a worldwide level, and discloses extensive information concerning the presence of Substances of Very High Concern (SVHC) in all of these products.

Product Environmental Profile (PEP)

Schneider Electric publishes complete set of environmental data, including carbon footprint and energy consumption data for each of the life cycle phases on all of its products, in compliance with the ISO 14025 PEP ecopassport program. Product environmental profile is especially useful for monitoring, controlling, saving energy, and/or reducing carbon emissions.

End of Life Instructions (EoLI)

The end of life instructions are in compliance with the Waste Electrical and Electronic Equipment (WEEE) directive and provide:

- Recyclability rates for Schneider Electric products.
- Guidance to mitigate personnel hazards during the dismantling of products and before recycling operations.
- Part identification for recycling or for selective treatment, to mitigate environmental hazards/incompatibility with standard recycling processes.

Routine End-User Maintenance Procedures

What's in This Part

Device NII_ZA_1: Check the General Condition of the Device	22
Mechanism NII_ZA_1: Operate the Device Manually and Electrically	28
Mechanism NII_ZA_2: Charge the Device Electrically with MCH Gear Motor	34
Mechanism NII_ZA_3: Check the Complete Closing of Device Poles	38
Auxiliaries NII_ZA_1: Check Auxiliary Wiring and Insulation	40
Control Unit NII_ZA_1: Check Device Tripping and Operation of SDE Fault- Trip Indication Contacts	43
Control Unit NII_ZA_2: Check Ground-Fault Protection Function (MicroLogic Active 6.0)	48
Control Unit NII_ZA_3: Check Operation of Energy Reduction Maintenance Settings (ERMS)	51
Device Locking NII_ZA_1: Operate Device Keylocks.....	55
Device Locking NII_ZA_2: Operate Device Padlocks	58
Chassis NII_ZA_1: Check Device Racking Operation.....	61
Chassis NII_ZA_2: Check IBPO Racking Interlock (MasterPacT MTZ2/ MTZ3)	66
Chassis Locking NII_ZA_1: Operate Chassis Keylocking System	68
Chassis Locking NII_ZA_2: Operate Chassis Padlocking System	72
Mechanical Interlocking NII_ZA_1: Operate Interlocking Systems	75

Device NII_ZA_1: Check the General Condition of the Device

Safety Instructions

DANGER

HAZARD OF ELECTRIC SHOCK, EXPLOSION, OR ARC FLASH

- Apply appropriate personal protective equipment (PPE) and follow safe electrical work practices. See NFPA 70E, CSA Z462, NOM 029-STPS, or local equivalent.
- This equipment must only be installed and serviced by qualified electrical personnel.
- Unless specified otherwise in the maintenance procedures, all operations (inspection, test, and preventive maintenance) must be carried out with the device, the chassis, and the auxiliary circuits de-energized.
- Check that the device and the chassis are de-energized on the upstream and downstream terminals.
- Always use a properly rated voltage sensing device to confirm that the device, the chassis, and the auxiliary circuits are de-energized.
- Install safety barriers and display a danger sign.
- During the tests, it is strictly forbidden for anyone to touch the device, the chassis, or the conductors while voltage is applied.
- Before turning on power to this equipment, check that all connections are made with the correct tightening torque and the device is off (open position).
- Before turning on power to this equipment, put all devices, doors, and covers back in place.
- Before turning on power to this equipment, beware of potential hazards and carefully inspect the work area for tools and objects that may have been left inside the equipment.

Failure to follow these instructions will result in death or serious injury.

Procedure Definition

Procedure characteristics	Description
Action	Visually check that there are no visible signs of aging or damage on the different parts of the device.
Goal	Verify the general condition of the device in operation or following long storage.
Frequency	Refer to Recommended Frequency for the Routine End-User Maintenance Program, page 14.
Special indications	–
Necessary tools	–
Related documents, page 6	<ul style="list-style-type: none"> MasterPacT MTZ1 IEC Circuit Breakers with MicroLogic Active Control Unit - User Guide MasterPacT MTZ2/MTZ3 IEC Circuit Breakers with MicroLogic Active Control Unit - User Guide MasterPacT MTZ1 3P/4P - Front Cover - Instruction Sheet MasterPacT MTZ2 3P/4P - Front Cover - Instruction Sheet MasterPacT MTZ1/MTZ2/MTZ3 - MicroLogic Transparent Cover - Instruction Sheet MicroLogic Active - Spare Battery - Instruction Sheet

Preliminary Conditions



The device must comply with the conditions specified below. Refer to the *MasterPacT MTZ User Guides* to find instructions for operating the device.

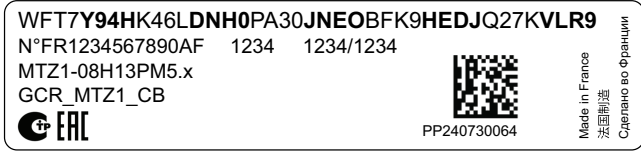
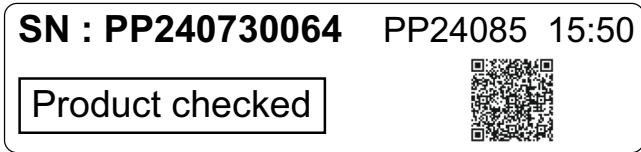
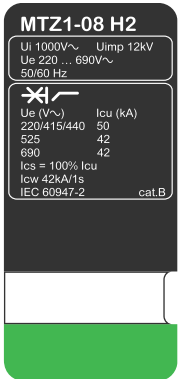

Device installation type	Position of poles	Mechanism	Device position in the chassis
Fixed	Open	Discharged	N/A
Drawout	Open	Discharged	Disconnected

Checking the Front Cover of the Device

Step	Action	Corrective action
1	<p>Check presence of all screws on the front cover:</p> <ul style="list-style-type: none"> For MasterPacT MTZ1: four screws. For MasterPacT MTZ2/MTZ3: five screws. 	<p>If any screws are missing, replace the front cover (refer to <i>MasterPacT MTZ 3P/4P - Front Cover - Instruction Sheet</i>).</p> <p>Refer to the <i>MasterPacT MTZ Catalog</i> for spare parts.</p>
2	<p>Check that the front cover is not cracked, split open, or deformed.</p>	<p>If the front cover is damaged, replace it (refer to <i>MasterPacT MTZ 3P/4P - Front Cover - Instruction Sheet</i>).</p> <p>Refer to the <i>MasterPacT MTZ Catalog</i> for spare parts.</p>
3	<p>Check that the identification labels are present on the device and the chassis, including:</p> <ul style="list-style-type: none"> Product identification label  Product checked label  Rating plate  	<p>To replace the rating plate, contact your Schneider Electric Services representative.</p>
4	<p>If available, check the label indicating the date of the last maintenance operation.</p>	

Checking the MicroLogic Active Control Unit

Step	Action	Corrective action
1	Check that the transparent cover is in place.	<ul style="list-style-type: none"> If the transparent cover is not correctly mounted, remove it then mount it again (refer to <i>MasterPacT MTZ1/MTZ2/MTZ3 - MicroLogic Transparent Cover - Instruction Sheet</i>). If the transparent cover is missing or damaged, replace it. <p>Refer to the <i>MasterPacT MTZ Catalog</i> for spare parts.</p>
2	<p>To open the transparent cover, pull its upper right-hand side corner.</p>  <p>NOTE: The transparent cover must be opened to modify the protection settings locally or to access the USB-C port on the front of the MicroLogic Active control unit.</p> <p>At the end of each check when using the USB-C port:</p> <ol style="list-style-type: none"> Remove the cable from the USB-C port. Close the transparent cover completely. <p>The cover does not need to be opened when modifying the protection settings remotely.</p>	
3	<p>To test the internal battery or check LED functionality, press and hold the  button for less than 3 seconds. The trip cause LEDs and Status bar switch off for one second, and then do one of the following:</p> <ul style="list-style-type: none"> Switch on for two seconds: the battery is OK. Flash in sequence for two seconds: the battery is near the end of its life. Replace the battery. Do not light: replace the battery. <p>NOTE: This test must be carried out immediately after the replacement of the internal battery to check the correct functioning of the new battery. It can then be carried out at any time in the life of the internal battery.</p>	<ul style="list-style-type: none"> If one LED does not light up, contact your Schneider Electric Services representative. If the trip cause LEDs and Status bar light up in sequence, or the trip cause LEDs and Status bar do not light up: <ol style="list-style-type: none"> Replace the MicroLogic Active internal battery (refer to <i>MicroLogic Active - Spare Battery - Instruction Sheet</i>). Repeat the procedure. <p>If the problem persists, contact your Schneider Electric Services representative.</p>

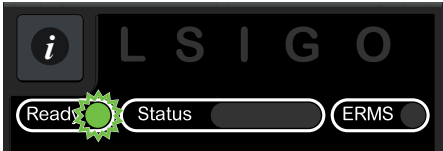
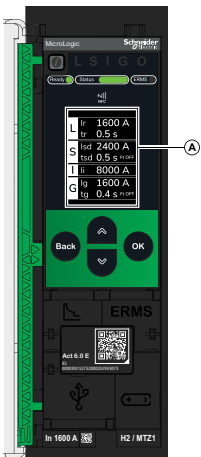
Step	Action	Corrective action
		
4	<p>Connect the MicroLogic Active control unit to a power supply.</p> <p>For example, connect the Mobile Power Pack external battery to the MicroLogic Active USB port.</p> 	
5	<p>Check that the Ready LED is flashing, meaning that the fault detection chain is working correctly.</p> 	<p>If the LED does not flash and no event message is displayed on the control unit, replace the MicroLogic Active control unit.</p>
6	<p>Check the legibility of the data and settings displayed on the MicroLogic Active display screen (A).</p>  <p>NOTE: The protection functions remain operational when the MicroLogic Active display screen is not operating correctly. Settings and data can be viewed on other interfaces, for example, EcoStruxure Power Commission software.</p>	<p>If the display is not legible, or if the contextual buttons are not operating correctly, replace the MicroLogic Active control unit.</p>

Cleaning the Device

NOTICE

HAZARD OF EQUIPMENT DAMAGE

Do not use pressurized cleaning products or products containing solvents (trichloroethane or trichloroethylene) such as WD40.

Failure to follow these instructions can result in equipment damage.

Pressurized cleaning products can cause the following damages:



- Removal of grease from inaccessible lubrication points. These areas are greased for the life of the device and cannot be regreased.
- Corrosion of points that are not regreased.
- Damage caused by the pressure applied by the cleaning product.
- Temperature rise due to the presence of an insulating solvent in the contact zones.
- Elimination of special protection.
- Deterioration of plastic materials.

Step	Action	Comment
1	Clean the device using a clean, dry cloth or a brush.	If there is excessive dust, contact your Schneider Electric Services representative.

Checking the Case of the Device and Chassis for Drawout Device

Step	Action	Corrective action
1	Check for cracks and change in color.	If there are cracks or change in color, contact your Schneider Electric Services representative.
2	<p>Check for traces of black smoke (indicating tripping due to a short-circuit) around the arc chutes and on the sides.</p>  <p>NOTE: For a fixed device, remove the additional support brackets, if necessary.</p>	If there are traces of black smoke, contact your Schneider Electric Services representative.

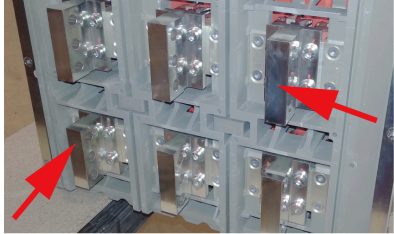
Checking Connections

Step	Action	Corrective action
1	<p>Visually check the device terminals for a change in color indicating abnormal temperature rise.</p> <ul style="list-style-type: none"> • For fixed devices: customer terminals • For drawout devices: <ul style="list-style-type: none"> ◦ Customer terminals  <ul style="list-style-type: none"> ◦ Internal terminals  <ul style="list-style-type: none"> ◦ Disconnecting contact clusters 	<p>If there is a change in color on device terminals and you are qualified, follow procedure Power Connections NIII_ZA_1, page 149. Otherwise, contact your Schneider Electric Services representative.</p>
2	<p>Visually check the condition of cable insulation (for example, change in color, cracks, or cable shrinkage).</p>	<p>If the cables show signs of damage to insulation and you are qualified, follow procedure Power Connections NIII_ZA_1, page 149. Otherwise, contact your Schneider Electric Services representative.</p>

Checking Connections in Corrosive Environments

In the case of corrosive environments, contact your Schneider Electric Services representative.

For example, devices may be used in places where sulfur dioxide (SO₂) or hydrogen sulphide (H₂S) are present, such as, steel works, paper mills, synthetic fibers, refineries, and sulfur chemical plants. Corrosive chemicals can have an impact on the integrity of the device:

- Excessive temperature rise causes sulfurization (oxidation) of silver and results in destruction of contacts.
- Contact with SO₂ and H₂S blackens solid silver and silver-plated contacts which increases contact resistance and temperature.

Mechanism NII_ZA_1: Operate the Device Manually and Electrically

Safety Instructions

⚡ ⚠ DANGER

HAZARD OF ELECTRIC SHOCK, EXPLOSION, OR ARC FLASH

- Apply appropriate personal protective equipment (PPE) and follow safe electrical work practices. See NFPA 70E, CSA Z462, NOM 029-STPS, or local equivalent.
- This equipment must only be installed and serviced by qualified electrical personnel.
- Unless specified otherwise in the maintenance procedures, all operations (inspection, test, and preventive maintenance) must be carried out with the device, the chassis, and the auxiliary circuits de-energized.
- Check that the device and the chassis are de-energized on the upstream and downstream terminals.
- Always use a properly rated voltage sensing device to confirm that the device, the chassis, and the auxiliary circuits are de-energized.
- Install safety barriers and display a danger sign.
- During the tests, it is strictly forbidden for anyone to touch the device, the chassis, or the conductors while voltage is applied.
- Before turning on power to this equipment, check that all connections are made with the correct tightening torque and the device is off (open position).
- Before turning on power to this equipment, put all devices, doors, and covers back in place.
- Before turning on power to this equipment, beware of potential hazards and carefully inspect the work area for tools and objects that may have been left inside the equipment.

Failure to follow these instructions will result in death or serious injury.

Procedure Definition

Procedure characteristics	Description
Action	Check the operation of: <ul style="list-style-type: none"> • Charging mechanism using the spring charging handle. • Device opening and closing mechanism by using: <ul style="list-style-type: none"> ◦ The pushbuttons. ◦ The XF/MX/MN voltage releases. • The position indicators. • The CDM operation counter, if present.
Goal	Verify that the device can be opened/closed manually and electrically.
Frequency	Refer to Recommended Frequency for the Routine End-User Maintenance Program, page 14.
Special indications	Connect the XF/MX/MN voltage releases to the power supply.

Procedure characteristics	Description
Necessary tools	<ul style="list-style-type: none"> Adjustable external power supply Voltmeter LV847074SP terminal block
Related documents, page 6	<ul style="list-style-type: none"> MasterPacT MTZ1 IEC Circuit Breakers with MicroLogic Active Control Unit - User Guide MasterPacT MTZ2/MTZ3 IEC Circuit Breakers with MicroLogic Active Control Unit - User Guide MasterPacT MTZ1 - CDM Operation Counter - Instruction Sheet MasterPacT MTZ2/MTZ3 - CDM Operation Counter - Instruction Sheet MasterPacT MTZ1/MTZ2/MTZ3 - MN-MX-XF Voltage Releases - Instruction Sheet MasterPacT MTZ1/MTZ2/MTZ3 - Auxiliary Terminals - Instruction Sheet



Preliminary Conditions

The device must comply with the conditions specified below. Refer to the *MasterPacT MTZ User Guides* to find instructions for operating the device.

Device installation type	Position of poles	Mechanism	Device position in the chassis
Fixed	Open	Discharged	N/A
Drawout	Open	Discharged	Test

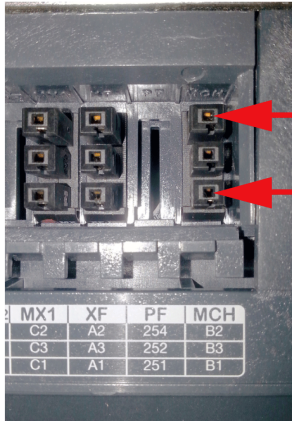
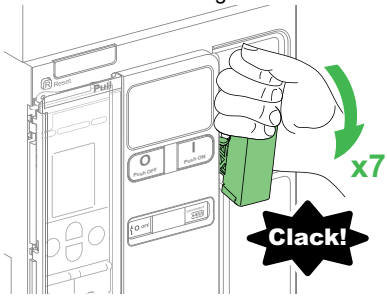
Checking Manual Opening/Closing of the Device

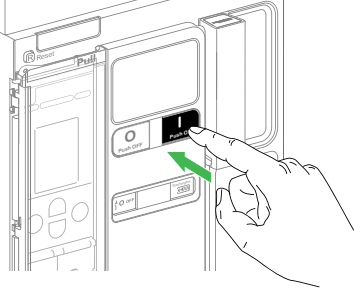
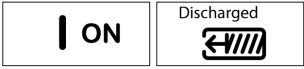
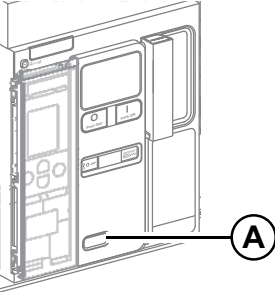
Step	Action	Corrective action																
1	<p>For fixed devices equipped with the MCH gear motor, disconnect the auxiliary circuit for the MCH gear motor (terminals B1 and B2).</p>  <table border="1" data-bbox="272 1556 517 1635"> <tr> <td>MX1</td> <td>XF</td> <td>PF</td> <td>MCH</td> </tr> <tr> <td>C2</td> <td>A2</td> <td>254</td> <td>B2</td> </tr> <tr> <td>C3</td> <td>A3</td> <td>252</td> <td>B3</td> </tr> <tr> <td>C1</td> <td>A1</td> <td>251</td> <td>B1</td> </tr> </table>	MX1	XF	PF	MCH	C2	A2	254	B2	C3	A3	252	B3	C1	A1	251	B1	
MX1	XF	PF	MCH															
C2	A2	254	B2															
C3	A3	252	B3															
C1	A1	251	B1															
2	<p>Manually charge the mechanism by pulling the spring charging handle down seven times.</p> <p>When the spring charging handle no longer resists, the mechanism is charged.</p> 																	

Step	Action	Corrective action
3	<p>Press the closing pushbutton to close the device.</p>  <p>The device closes.</p>	<p>If the device does not close, refer to troubleshooting in the appendix, page 155.</p> <p>If the problem persists, contact your Schneider Electric Services representative.</p>
4	<p>Check that the indicators show that the device is closed, and the mechanism is discharged.</p> 	<p>If the indicators show different information, refer to troubleshooting in the appendix, page 155.</p> <p>If the problem persists, contact your Schneider Electric Services representative.</p>
5	<p>Check that the CDM operation counter (A) increments.</p> 	<p>If the CDM operation counter does not increment, check it is correctly installed (refer to <i>MasterPacT MTZ - CDM Operation Counter - Instruction Sheet</i>).</p> <p>If the CDM operation counter does not increment and is correctly installed, replace it.</p>
6	<p>Charge the mechanism again.</p> <p>Check that the indicators show that the device is closed, and the mechanism is charged and not ready-to-close.</p> 	<p>If the indicators show different information, refer to troubleshooting in the appendix, page 155.</p> <p>If the problem persists, contact your Schneider Electric Services representative.</p>
7	<p>Press the opening pushbutton to open the device.</p> <p>The device opens.</p>	<p>If the device does not open, refer to troubleshooting in the appendix, page 155.</p> <p>If the problem persists, contact your Schneider Electric Services representative.</p>
8	<p>Check that the indicators show that the device is open, and the mechanism is charged and ready-to-close.</p> 	<p>If the indicators show different information, refer to troubleshooting in the appendix, page 155.</p> <p>If the problem persists, contact your Schneider Electric Services representative.</p>



Checking Electrical Closing with the XF Closing Voltage Release

⚠️⚠️ DANGER

HAZARD OF ELECTRIC SHOCK

When using the adjustable external power supply, take all suitable measures to protect against electric shock.

Failure to follow these instructions will result in death or serious injury.

Step	Action	Corrective action
1	Reconnect the auxiliary circuit for the MCH gear motor (terminals B1 and B2).	
2	<p>Press the external pushbutton to close the device.</p> <p>The device closes.</p>	<p>If the device does not close, it can be due to external conditions. Refer to troubleshooting in the appendix, page 155.</p> <p>If the external conditions are correct:</p> <ul style="list-style-type: none"> For a fixed device: replace the XF closing voltage release (refer to <i>MasterPacT MTZ1/MTZ2/MTZ3 - MN-MX-XF Voltage Releases - Instruction Sheet</i>) and do the procedure again. For a drawout device, check that the XF closing voltage release operates correctly as follows: <ol style="list-style-type: none"> Put the device in the withdrawn position. Insert a replacement LV847074SP terminal block in the appropriate location on the device.  <ol style="list-style-type: none"> Connect the XF closing voltage release to the adjustable external power supply set to U_n. <ul style="list-style-type: none"> If the device closes, replace the auxiliary terminal block (refer to <i>MasterPacT MTZ1/MTZ2/MTZ3 - Auxiliary Terminals - Instruction Sheet</i>) and do the procedure again with the device in the test position. If the device does not close, replace the XF closing voltage release (refer to <i>MasterPacT MTZ1/MTZ2/MTZ3 - MN-MX-XF Voltage Releases - Instruction Sheet</i>) and do the procedure again. <p>Refer to the <i>MasterPacT MTZ Catalog</i> for spare parts.</p> <p>If the problem persists, contact your Schneider Electric Services representative.</p>
3	<p>Check that the indicators show that the device is closed and check the mechanism status:</p> <ul style="list-style-type: none"> Without MCH gear motor, the mechanism is discharged. <div style="display: flex; justify-content: space-around; align-items: center;"> <div style="border: 1px solid black; padding: 5px; text-align: center;"> <p>ON</p> </div> <div style="border: 1px solid black; padding: 5px; text-align: center;"> <p>Discharged</p>  </div> </div> <ul style="list-style-type: none"> With MCH gear motor, the mechanism is charged. <div style="display: flex; justify-content: space-around; align-items: center;"> <div style="border: 1px solid black; padding: 5px; text-align: center;"> <p>ON</p> </div> <div style="border: 1px solid black; padding: 5px; text-align: center; background-color: yellow;"> <p>Charged</p> <p>OK</p> </div> </div>	<p>If the indicators show different information, refer to troubleshooting in the appendix, page 155.</p> <p>If the problem persists, contact your Schneider Electric Services representative.</p>
4	Check that the CDM operation counter increments.	<p>If the CDM operation counter does not increment, check it is correctly installed (refer to <i>MasterPacT MTZ - CDM Operation Counter - Instruction Sheet</i>).</p> <p>If the CDM operation counter is correctly installed, replace it.</p>

Checking Electrical Opening with the MX Opening Voltage Release







 **DANGER**

HAZARD OF ELECTRIC SHOCK

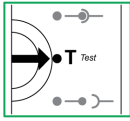

When using the adjustable external power supply, take all suitable measures to protect against electric shock.

Failure to follow these instructions will result in death or serious injury.

Execute the following procedure for MX1 then MX2, if connected.

Step	Action	Corrective action
1	<p>For drawout devices, check that the device is in the test position.</p> 	
2	<p>Press the external pushbutton to open the device.</p> <p>The device opens.</p>	<p>If the device does not open, it can be due to external conditions. Refer to troubleshooting in the appendix, page 155.</p> <p>If the external conditions are correct:</p> <ul style="list-style-type: none"> For a fixed device: replace the MX opening voltage release (refer to <i>MasterPacT MTZ1/MTZ2/MTZ3 - MN-MX-XF Voltage Releases - Instruction Sheet</i>) and do the procedure again. For a drawout device, check that the MX closing voltage release operates correctly as follows: <ol style="list-style-type: none"> Put the device in the withdrawn position. Insert an LV847074SP terminal block in the appropriate location on the device.  <ol style="list-style-type: none"> Connect the MX opening voltage release to the adjustable external power supply set to Un. <ul style="list-style-type: none"> If the device opens, replace the auxiliary terminal block (refer to <i>MasterPacT MTZ1/MTZ2/MTZ3 - Auxiliary Terminals - Instruction Sheet</i>) and do the procedure again with the device in the test position. If the device does not open, replace the MX opening voltage release and do the procedure again with the device in the test position. <p>Refer to the <i>MasterPacT MTZ Catalog</i> for spare parts.</p> <p>If the problem persists, contact your Schneider Electric Services representative.</p>
3	<p>Check that the indicators show that the device is open and check the mechanism status:</p> <ul style="list-style-type: none"> Without MCH gear motor, the mechanism is discharged. <div style="display: flex; align-items: center; margin-top: 5px;"> <div style="background-color: green; color: white; padding: 5px; text-align: center;">  OFF </div> <div style="border: 1px solid black; padding: 5px; margin-left: 10px;"> Discharged  </div> </div> With MCH gear motor, the mechanism is charged. <div style="display: flex; align-items: center; margin-top: 5px;"> <div style="background-color: green; color: white; padding: 5px; text-align: center;">  OFF </div> <div style="background-color: yellow; padding: 5px; margin-left: 10px; text-align: center;">  Charged OK </div> </div> 	<p>If the indicators show different information, refer to troubleshooting in the appendix, page 155.</p> <p>If the problem persists, contact your Schneider Electric Services representative.</p>

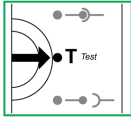
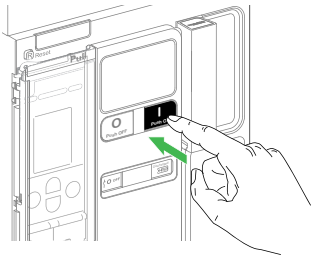
Checking Electrical Opening with the MN Undervoltage Release

Step	Action	Corrective action
1	<p>For drawout devices, check that the device is in the test position.</p> 	
2	<ul style="list-style-type: none"> Without MCH gear motor: manually charge the mechanism by pulling the spring charging handle down seven times. When the spring charging handle no longer resists, the mechanism is charged. With MCH gear motor: the mechanism is automatically charged. 	
3	<p>Press the external pushbutton to close the device.</p>  <p>The device closes.</p>	<p>If the device does not close, check the MN undervoltage release wiring and power supply, and refer to troubleshooting in the appendix, page 155.</p>
4	<ul style="list-style-type: none"> For fixed devices: <ul style="list-style-type: none"> Remove the fixed auxiliary terminal block. Then, the device opens. For drawout devices: <ul style="list-style-type: none"> Rack-out the device to the disconnected position. Then, the device opens. 	<p>If the device does not open, replace the MN undervoltage release (refer to <i>MasterPacT MTZ1/MTZ2/MTZ3 - MN-MX-XF Voltage Releases - Instruction Sheet</i>).</p> <p>Refer to the <i>MasterPacT MTZ Catalog</i> for spare parts.</p> <p>If the problem persists, contact your Schneider Electric Services representative.</p>
5	<p>Check that the indicators show that the device is open and check the mechanism status:</p> <ul style="list-style-type: none"> Without MCH gear motor, the mechanism is discharged.  With MCH gear motor, the mechanism is charged and not ready-to-close.  	<p>If the indicators show different information, refer to troubleshooting in the appendix, page 155.</p> <p>If the problem persists, contact your Schneider Electric Services representative.</p>

Mechanism NII_ZA_2: Charge the Device Electrically with MCH Gear Motor

Safety Instructions

⚡⚠ DANGER

HAZARD OF ELECTRIC SHOCK, EXPLOSION, OR ARC FLASH

- Apply appropriate personal protective equipment (PPE) and follow safe electrical work practices. See NFPA 70E, CSA Z462, NOM 029-STPS, or local equivalent.
- This equipment must only be installed and serviced by qualified electrical personnel.
- Unless specified otherwise in the maintenance procedures, all operations (inspection, test, and preventive maintenance) must be carried out with the device, the chassis, and the auxiliary circuits de-energized.
- Check that the device and the chassis are de-energized on the upstream and downstream terminals.
- Always use a properly rated voltage sensing device to confirm that the device, the chassis, and the auxiliary circuits are de-energized.
- Install safety barriers and display a danger sign.
- During the tests, it is strictly forbidden for anyone to touch the device, the chassis, or the conductors while voltage is applied.
- Before turning on power to this equipment, check that all connections are made with the correct tightening torque and the device is off (open position).
- Before turning on power to this equipment, put all devices, doors, and covers back in place.
- Before turning on power to this equipment, beware of potential hazards and carefully inspect the work area for tools and objects that may have been left inside the equipment.

Failure to follow these instructions will result in death or serious injury.

Procedure Definition

Procedure characteristics	Description
Action	<ul style="list-style-type: none"> • Check the operation of the MCH gear motor and its charging time. • Check the operation of the CH contact of the MCH gear motor. • Check the number of charging operations of MCH gear motor from a mobile device.
Goal	Verify that the device charges electrically.
Frequency	Refer to Recommended Frequency for the Routine End-User Maintenance Program, page 14.
Special indications	Connect the MCH gear motor to the power supply.

Procedure characteristics	Description
Necessary tools	<ul style="list-style-type: none"> • Stopwatch • Ohmmeter • LV847074SP terminal block
Related documents, page 6	<ul style="list-style-type: none"> • <i>MasterPacT MTZ1 IEC Circuit Breakers with MicroLogic Active Control Unit - User Guide</i> • <i>MasterPacT MTZ2/MTZ3 IEC Circuit Breakers with MicroLogic Active Control Unit - User Guide</i> • <i>MasterPacT MTZ - MicroLogic Active Control Unit - User Guide</i> • <i>MasterPacT MTZ IEC Circuit Breakers with MicroLogic Active Control Unit - Maintenance Guide</i> • <i>MasterPacT MTZ1 - MCH Gear Motor - Instruction Sheet for operating limits</i> • <i>MasterPacT MTZ2/MTZ3 - MCH Gear Motor - Instruction Sheet</i> • <i>MasterPacT MTZ1/MTZ2/MTZ3 - Auxiliary Terminals - Instruction Sheet</i>

Preliminary Conditions

The device must comply with the conditions specified below. Refer to the *MasterPacT MTZ User Guides* to find instructions for operating the device.

Device installation type	Position of poles	Mechanism	Device position in the chassis
Fixed	Open	Discharged	N/A
Drawout	Open	Discharged	Test

MCH Gear Motor Wiring Diagram

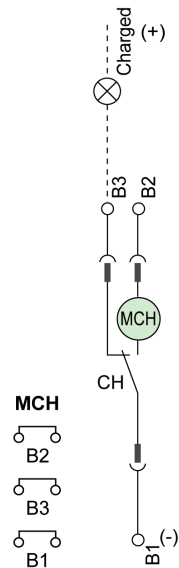



MCH Gear Motor Charging Time Definition

The charging time is the time elapsed between the closing order and the moment when the mechanism is fully charged.

The charging time during the closing operation does not exceed 6 seconds.

Checking Operation of MCH Gear Motor and CH Contact

Step	Action	Corrective action
1	Remove the MCH gear motor power supply.	
2	Do an opening/closing/opening cycle to discharge the mechanism.	
3	With the device in the open position and the mechanism discharged, check electrical continuity between terminals B1-B2, and electrical non-continuity between terminals B1-B3.	<p>In case of electrical non-continuity between terminals B1-B2, or electrical continuity between terminals B1-B3:</p> <ul style="list-style-type: none"> • For a fixed device: replace the MCH gear motor (refer to <i>MasterPacT MTZ - MCH Gear Motor - Instruction Sheet</i>) and do the procedure again. • For a drawout device, check that the MCH gear motor operates correctly as follows: <ol style="list-style-type: none"> 1. Put the device in the withdrawn position. 2. Insert an LV847074SP terminal block at the appropriate location on the device. <div style="text-align: center;">  </div> <ol style="list-style-type: none"> 3. Check the electrical continuity between terminals B1-B2 and non-continuity between terminals B1-B3 directly on the LV847074SP terminal block. <ul style="list-style-type: none"> ◦ If the check is correct, replace the auxiliary terminal block (refer to <i>MasterPacT MTZ1/MTZ2/MTZ3 - Auxiliary Terminals - Instruction Sheet</i>) and do the procedure again with the device in the test position. ◦ If the check is not correct, replace the MCH gear motor and do the procedure again with the device in the test position. <p>Refer to the <i>MasterPacT MTZ Catalog</i> for spare parts.</p> <p>If the problem persists, contact your Schneider Electric Services representative.</p>
4	Manually charge the mechanism.	
5	Reconnect the MCH gear motor power supply.	
6	<p>Start the stopwatch while pressing the closing pushbutton.</p> <div style="text-align: center;">  </div> <p>The device closes and the mechanism is automatically charged.</p>	<p>If the device does not close, refer to troubleshooting in the appendix, page 155.</p> <p>If the problem persists, contact your Schneider Electric Services representative.</p>
7	Stop the stopwatch when the mechanism is totally charged.	

Step	Action	Corrective action
8	Check the mechanism charging time: it must not exceed 6 seconds.	<p>If the charging time exceeds 6 seconds, do the procedure three more times from the beginning.</p> <p>If the charging time does not improve, follow the procedure Mechanism NIII_ZA_1 to check the voltage supply of the MCH gear motor, page 79.</p> <p>If there is still no improvement, replace the MCH gear motor and measure the charging time again.</p> <p>If the problem persists, contact your Schneider Electric Services representative.</p>
9	Check electrical continuity between terminals B1-B3.	In case of electrical non-continuity between terminals B1-B3, see the corrective action concerning electrical continuity above.

Mechanism NII_ZA_3: Check the Complete Closing of Device Poles

Safety Instructions

⚡ ⚠ DANGER

HAZARD OF ELECTRIC SHOCK, EXPLOSION, OR ARC FLASH

- Apply appropriate personal protective equipment (PPE) and follow safe electrical work practices. See NFPA 70E, CSA Z462, NOM 029-STPS, or local equivalent.
- This equipment must only be installed and serviced by qualified electrical personnel.
- Unless specified otherwise in the maintenance procedures, all operations (inspection, test, and preventive maintenance) must be carried out with the device, the chassis, and the auxiliary circuits de-energized.
- Check that the device and the chassis are de-energized on the upstream and downstream terminals.
- Always use a properly rated voltage sensing device to confirm that the device, the chassis, and the auxiliary circuits are de-energized.
- Install safety barriers and display a danger sign.
- During the tests, it is strictly forbidden for anyone to touch the device, the chassis, or the conductors while voltage is applied.
- Before turning on power to this equipment, check that all connections are made with the correct tightening torque and the device is off (open position).
- Before turning on power to this equipment, put all devices, doors, and covers back in place.
- Before turning on power to this equipment, beware of potential hazards and carefully inspect the work area for tools and objects that may have been left inside the equipment.

Failure to follow these instructions will result in death or serious injury.

Procedure Definition



Procedure characteristics	Description
Action	Check that when the spring charging handle is pulled down with the device in the closed position and the mechanism charged, the device does not open.
Goal	Verify that the poles are closed and mechanically latched after closing the device manually.
Frequency	Refer to Recommended Frequency for the Routine End-User Maintenance Program, page 14.
Special indications	This check must be carried out manually. On fixed devices equipped with the MCH gear motor, disconnect the auxiliary circuit for the MCH gear motor (terminals B1 and B2).
Necessary tools	–
Related documents, page 6	<ul style="list-style-type: none"> • <i>MasterPacT MTZ1 IEC Circuit Breakers with MicroLogic Active Control Unit - User Guide</i> • <i>MasterPacT MTZ2/MTZ3 IEC Circuit Breakers with MicroLogic Active Control Unit - User Guide</i>

Preliminary Conditions

The device must comply with the conditions specified below. Refer to the *MasterPacT MTZ User Guides* to find instructions for operating the device.

Device installation type	Position of poles	Mechanism	Device position in the chassis
Fixed	Open	Discharged	N/A
Drawout	Open	Discharged	Disconnected

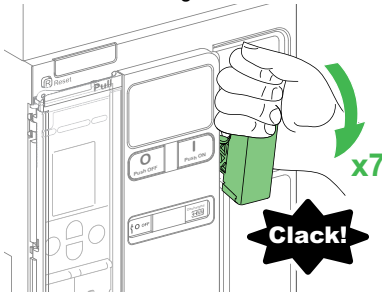
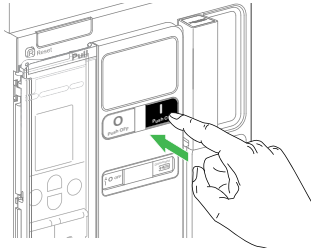
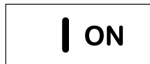
Checking Device Pole Complete Closing

Step	Action	Corrective action
1	<p>Manually charge the mechanism by pulling the spring charging handle down seven times.</p> <p>When the spring charging handle no longer resists, the mechanism is charged.</p> 	
2	<p>Press the closing pushbutton to close the device.</p>  <p>The device closes.</p>	<p>If the device does not close, refer to troubleshooting in the appendix, page 155.</p> <p>If the problem persists, contact your Schneider Electric Services representative.</p>
3	<p>Pull the spring charging handle down. The device must remain closed.</p> <p>The indicator shows </p>	<p>If the device opens (the indicator shows ) , the poles are not mechanically latched.</p> <p>Contact your Schneider Electric Services representative.</p>

Auxiliaries NII_ZA_1: Check Auxiliary Wiring and Insulation

Safety Instructions

 **DANGER**

HAZARD OF ELECTRIC SHOCK, EXPLOSION, OR ARC FLASH

- Apply appropriate personal protective equipment (PPE) and follow safe electrical work practices. See NFPA 70E, CSA Z462, NOM 029-STPS, or local equivalent.
- This equipment must only be installed and serviced by qualified electrical personnel.
- Unless specified otherwise in the maintenance procedures, all operations (inspection, test, and preventive maintenance) must be carried out with the device, the chassis, and the auxiliary circuits de-energized.
- Check that the device and the chassis are de-energized on the upstream and downstream terminals.
- Always use a properly rated voltage sensing device to confirm that the device, the chassis, and the auxiliary circuits are de-energized.
- Install safety barriers and display a danger sign.
- During the tests, it is strictly forbidden for anyone to touch the device, the chassis, or the conductors while voltage is applied.
- Before turning on power to this equipment, check that all connections are made with the correct tightening torque and the device is off (open position).
- Before turning on power to this equipment, put all devices, doors, and covers back in place.
- Before turning on power to this equipment, beware of potential hazards and carefully inspect the work area for tools and objects that may have been left inside the equipment.

Failure to follow these instructions will result in death or serious injury.

Procedure Definition

Procedure characteristics	Description
Action	Visually check external and internal wiring and insulation of control and indication auxiliaries.
Goal	Verify electrical continuity of auxiliary circuits and contact robustness.
Frequency	Refer to Recommended Frequency for the Routine End-User Maintenance Program, page 14.
Special indications	–
Necessary tools	Flat screwdriver, 3 mm
Related documents, page 6	<ul style="list-style-type: none"> • <i>MasterPacT MTZ1 IEC Circuit Breakers with MicroLogic Active Control Unit - User Guide</i> • <i>MasterPacT MTZ2/MTZ3 IEC Circuit Breakers with MicroLogic Active Control Unit - User Guide</i> • <i>MasterPacT MTZ1/MTZ2/MTZ3 - Auxiliary Terminals - Instruction Sheet</i>

Preliminary Conditions

The device must comply with the conditions specified below. Refer to the *MasterPacT MTZ User Guides* to find instructions for operating the device.

Device installation type	Position of poles	Mechanism	Device position in the chassis
Fixed	Open	Discharged	N/A
Drawout	Open	Discharged	Disconnected

Checking Terminal Block and Connector Wiring

⚠️ ⚠️ DANGER

HAZARD OF ELECTRIC SHOCK

Use a properly rated voltage sensing device to confirm that the PTE voltage measurement input is de-energized (V1, V2, V3 on UC4 terminal block, VN on UC3 terminal block).

Failure to follow these instructions will result in death or serious injury.

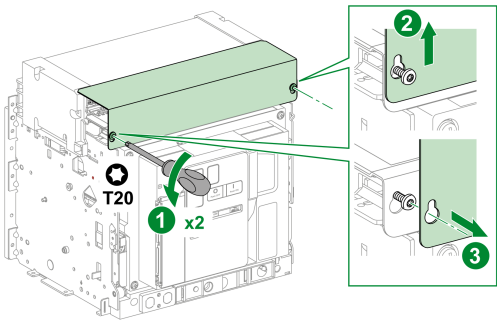
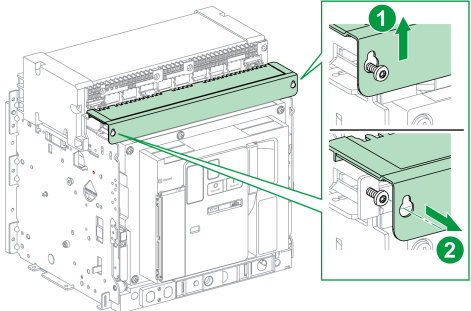
Step	Action	Corrective action
1	Remove the auxiliary terminal shield from a drawout device, if present. 	
2	Check that the external wiring is connected securely in the terminals.	If the connection is loose, replace the terminal blocks (refer to <i>MasterPacT MTZ1/MTZ2/MTZ3 - Auxiliary Terminals - Instruction Sheet</i>). Refer to the <i>MasterPacT MTZ Catalog</i> for spare parts.
3	Visually check the insulation of the external wiring.	If the wire insulation is cracked or damaged, replace the wires.
4	Check the terminal blocks for warping, damage, or change in color indicating abnormal temperature rise.	If there is a change in color, replace the terminal blocks (refer to <i>MasterPacT MTZ1/MTZ2/MTZ3 - Auxiliary Terminals - Instruction Sheet</i>).
5	For a MasterPacT MTZ2/MTZ3 drawout device, remove the terminal block identification plate. 	

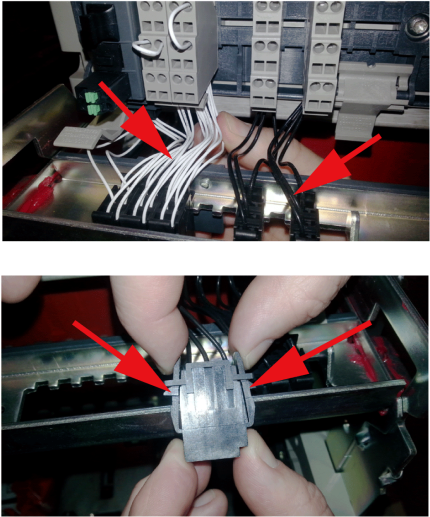
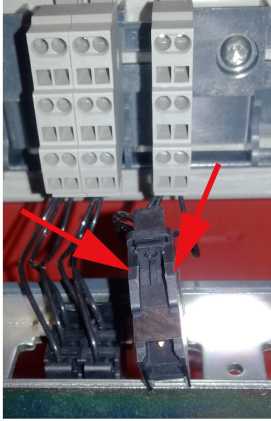
Step	Action	Corrective action
6	<p>Check the connection and wire insulation between the two parts of the terminal blocks.</p> 	<p>If the connection is loose or the wire insulation is cracked or damaged, replace the terminal blocks (refer to <i>MasterPacT MTZ1/MTZ2/MTZ3 - Auxiliary Terminals - Instruction Sheet</i>).</p>
7	<p>Check the mounting of connectors on the auxiliary crossbar.</p> 	<ul style="list-style-type: none"> • If a connector is damaged, replace the terminal block (refer to <i>MasterPacT MTZ1/MTZ2/MTZ3 - Auxiliary Terminals - Instruction Sheet</i>). • If the crossbar is damaged, contact your Schneider Electric Services representative.
8	<p>Put the terminal block identification plate and the auxiliary terminal shield back in place.</p>	

Control Unit NII_ZA_1: Check Device Tripping and Operation of SDE Fault-Trip Indication Contacts

Safety Instructions

⚠️⚠️ DANGER

HAZARD OF ELECTRIC SHOCK, EXPLOSION, OR ARC FLASH

- Apply appropriate personal protective equipment (PPE) and follow safe electrical work practices. See NFPA 70E, CSA Z462, NOM 029-STPS, or local equivalent.
- This equipment must only be installed and serviced by qualified electrical personnel.
- Unless specified otherwise in the maintenance procedures, all operations (inspection, test, and preventive maintenance) must be carried out with the device, the chassis, and the auxiliary circuits de-energized.
- Check that the device and the chassis are de-energized on the upstream and downstream terminals.
- Always use a properly rated voltage sensing device to confirm that the device, the chassis, and the auxiliary circuits are de-energized.
- Install safety barriers and display a danger sign.
- During the tests, it is strictly forbidden for anyone to touch the device, the chassis, or the conductors while voltage is applied.
- Before turning on power to this equipment, check that all connections are made with the correct tightening torque and the device is off (open position).
- Before turning on power to this equipment, put all devices, doors, and covers back in place.
- Before turning on power to this equipment, beware of potential hazards and carefully inspect the work area for tools and objects that may have been left inside the equipment.

Failure to follow these instructions will result in death or serious injury.

Procedure Definition

Procedure characteristics	Description
Action	<ul style="list-style-type: none"> • Check that the device trips. • Check that the fault-trip indication contacts, SDE1 (standard) and SDE2 (optional), operate correctly. • Check that the device resets mechanically (standard) and electrically (with optional RES remote reset).
Goal	Verify that the device operates fully (tripping mechanism, indication, and reset) when an electrical fault occurs.
Frequency	Refer to Recommended Frequency for the Routine End-User Maintenance Program, page 14.
Special indications	–

Procedure characteristics	Description
Necessary tools	<ul style="list-style-type: none"> LV847074SP terminal block Ohmmeter
Related documents, page 6	<ul style="list-style-type: none"> MasterPacT MTZ1 IEC Circuit Breakers with MicroLogic Active Control Unit - User Guide MasterPacT MTZ2/MTZ3 IEC Circuit Breakers with MicroLogic Active Control Unit - User Guide MasterPacT MTZ - MicroLogic Active Control Unit - User Guide EcoStruxure Power Commission Online Help MasterPacT MTZ2/MTZ3 - SDE2 Fault-Trip Indication Contact / RES Remote Reset - Instruction Sheet MasterPacT MTZ1/MTZ2/MTZ3 - Auxiliary Terminals - Instruction Sheet

Preliminary Conditions

The device must comply with the conditions specified below. Refer to the *MasterPacT MTZ User Guides* to find instructions for operating the device.

Device installation type	Position of poles	Mechanism	Device position in the chassis
Fixed	Closed	Discharged	N/A
Drawout	Closed	Discharged	Test

SDE Fault-Trip Indication Contact and RES Remote Reset Wiring Diagram

The optional RES electrical remote reset is not compatible with the optional SDE2 additional fault-trip indication contact because they are installed in the same physical place.

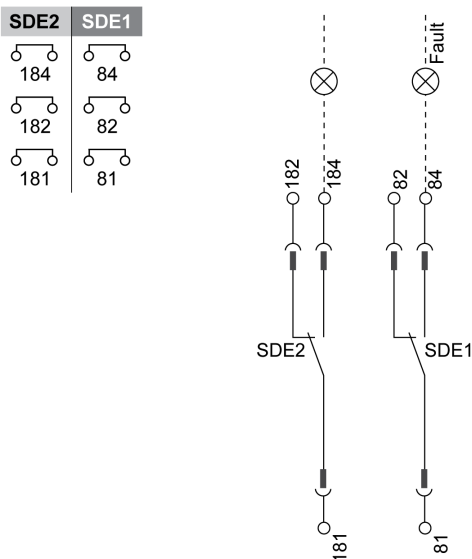

SDE1 and SDE2 fault-trip indication contacts

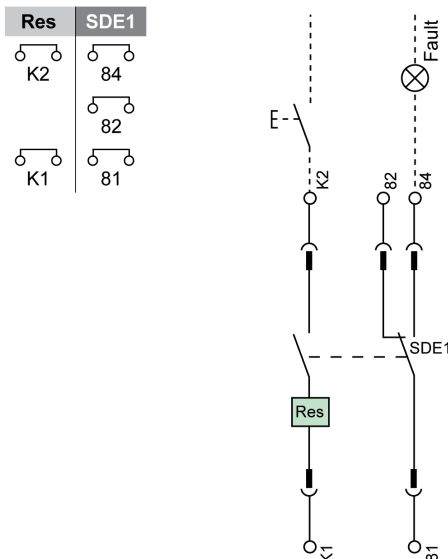

SDE1 fault-trip indication contact and RES remote reset





Checking the MicroLogic Active Trip Cause LEDs

Step	Action	Corrective action
1	<p>Press and hold the  button for less than 3 seconds. The trip cause LEDs and Status bar switch off for one second, and then do one of the following:</p> <ul style="list-style-type: none"> Switch on for two seconds: the battery is OK. Flash in sequence for two seconds: the battery is near the end of its life. Replace the battery. Do not light: replace the battery. 	<ul style="list-style-type: none"> If one LED does not light up, contact your Schneider Electric Services representative. If the trip cause LEDs and Status bar light up in sequence, or the trip cause LEDs and Status bar do not light up, refer to Step 3 when checking the MicroLogic Active control unit in procedure Device NII_ZA_1, page 24.

Checking Operation of SDE Fault-Trip Indication Contact

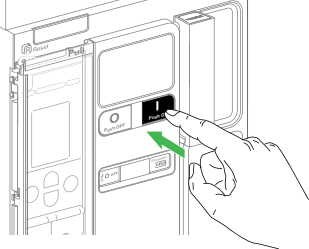
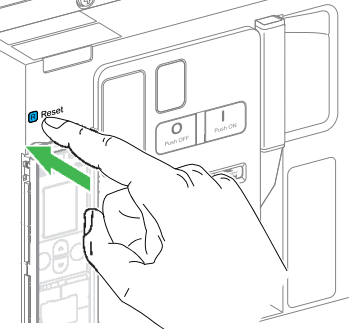
Step	Action	Corrective action
1	With the device in tripped position, check electrical continuity between terminals 81-84 on SDE1 contact.	<p>In case of electrical non-continuity between terminals:</p> <ul style="list-style-type: none"> For a fixed device, contact your Schneider Electric Services representative. For a drawout device, check that the SDE1 contact operates correctly, as follows: <ol style="list-style-type: none"> Put the device in the withdrawn position. Insert an LV847074SP terminal block at the appropriate location on the device.  <ol style="list-style-type: none"> Check the electrical continuity directly on the LV847074SP terminal block: <ul style="list-style-type: none"> If the SDE1 contact operates correctly, replace the auxiliary terminal block installed on the chassis (refer to <i>MasterPacT MTZ1/MTZ2/MTZ3 - Auxiliary Terminals - Instruction Sheet</i>) and do the procedure again with the device in the test position. If the SDE1 contact does not operate correctly, contact your Schneider Electric Services representative.
2	With the device in tripped position, check electrical continuity between terminals 181-184 on SDE2 contact, if installed.	<p>In case of electrical non-continuity between terminals:</p> <ul style="list-style-type: none"> For a fixed MasterPacT MTZ1 device, contact your Schneider Electric Services representative. For a fixed MasterPacT MTZ2/MTZ3 device: replace the SDE2 contact (refer to <i>MasterPacT MTZ2/MTZ3 - SDE2 Fault-Trip Indication Contact / RES Remote Reset - Instruction Sheet</i>) and do the procedure again.

Step	Action	Corrective action
		<ul style="list-style-type: none"> • For a drawout device, check that the SDE2 contact operates correctly, as follows: <ol style="list-style-type: none"> 1. Put the device in the withdrawn position. 2. Insert an LV847074SP terminal block in the appropriate location on the device.  <ol style="list-style-type: none"> 3. Check the electrical continuity directly on the LV847074SP terminal block: <ul style="list-style-type: none"> ◦ If the SDE2 contact operates correctly, replace the auxiliary terminal block (refer to <i>MasterPacT MTZ1/MTZ2/MTZ3 - Auxiliary Terminals - Instruction Sheet</i>) and do the procedure again with the device in the test position. ◦ If the SDE2 contact does not operate correctly: <ul style="list-style-type: none"> – For MasterPacT MTZ1, contact your Schneider Electric Services representative. – For MasterPacT MTZ2/MTZ3, replace the SDE2 contact (refer to <i>MasterPacT MTZ2/MTZ3 - SDE2 Fault-Trip Indication Contact / RES Remote Reset - Instruction Sheet</i>).
3	<p>Press the closing pushbutton.</p>  <ul style="list-style-type: none"> • If the device is configured with the RAR automatic reset option, the device closes. • If the device is not configured with the RAR automatic reset option, the device must not close. 	<p>If the device does not operate as expected, contact your Schneider Electric Services representative.</p>
4	<p>Press the blue fault-trip reset button on the front cover to reset.</p> 	<p>If the blue fault-trip reset button does not reset, contact your Schneider Electric Services representative.</p>
5	<p>Check electrical continuity between terminals 81-82 on SDE1 contact.</p>	<p>In case of electrical non-continuity between terminals, refer to corrective action in step 1.</p>
6	<p>Check electrical continuity between terminals 181-182 on SDE2 contact, if installed.</p>	<p>In case of electrical non-continuity between terminals, refer to corrective action in step 2.</p>
7	<p>Check that the log and the trip/test counter are recorded in control unit log by using display screen or EcoStruxure Power Commission software.</p>	
8	<p>Press and hold the  button on the control unit for 3 seconds to reset the trip cause LEDs.</p>	

Checking Operation of Optional RES Remote Reset

⚠ DANGER

HAZARD OF ELECTRIC SHOCK, EXPLOSION OR ARC FLASH

Take all measures necessary to avoid the risk of electrocution when the external power supply voltage is greater than 30 Vac or 40 Vdc.

Failure to follow these instructions will result in death or serious injury.

Step	Action	Corrective Action
1	<p>With the device in tripped position, press the Remote Reset pushbutton connected to the RES Remote Reset option.</p> <p>Result: The blue fault trip button on the front cover must return to the reset position, pushed in the device.</p>	<p>If the blue fault trip button remains in the trip position, it can be due to external conditions. Refer to troubleshooting, page 155.</p> <p>If the external conditions are correct:</p> <ul style="list-style-type: none"> • For a MasterPacT MTZ1 device: contact your Schneider Electric Services representative. • For a MasterPacT MTZ2/MTZ3 fixed device: replace the RES contact (refer to <i>MasterPacT MTZ2/MTZ3 - SDE2 Fault-Trip Indication Contact / RES Remote Reset - Instruction Sheet</i>) and do the procedure again. • For a MasterPacT MTZ2/MTZ3 drawout device, check that the RES contact operates correctly, as follows: <ol style="list-style-type: none"> 1. Put the device in the withdrawn position. 2. Insert an LV847074SP terminal block at the appropriate location on the device.  <ol style="list-style-type: none"> 3. Apply the RES voltage supply on the LV847074SP terminal block. 4. Close the device. 5. Trip the device by launching an automatic trip curve test, page 120 in EcoStruxure Power Commission software: <ul style="list-style-type: none"> ◦ If the RES remote reset option resets the device, replace the auxiliary terminal block (refer to <i>MasterPacT MTZ1/MTZ2/MTZ3 - Auxiliary Terminals - Instruction Sheet</i>) and do the procedure again with the device in the test position. ◦ If the RES remote reset option does not reset the device, replace the RES contact (refer to <i>MasterPacT MTZ2/MTZ3 - SDE2 Fault-Trip Indication Contact / RES Remote Reset - Instruction Sheet</i>) and do the procedure again.

Control Unit NII_ZA_2: Check Ground-Fault Protection Function (MicroLogic Active 6.0)

Safety Instructions

DANGER

HAZARD OF ELECTRIC SHOCK, EXPLOSION, OR ARC FLASH

- Apply appropriate personal protective equipment (PPE) and follow safe electrical work practices. See NFPA 70E, CSA Z462, NOM 029-STPS, or local equivalent.
- This equipment must only be installed and serviced by qualified electrical personnel.
- Unless specified otherwise in the maintenance procedures, all operations (inspection, test, and preventive maintenance) must be carried out with the device, the chassis, and the auxiliary circuits de-energized.
- Check that the device and the chassis are de-energized on the upstream and downstream terminals.
- Always use a properly rated voltage sensing device to confirm that the device, the chassis, and the auxiliary circuits are de-energized.
- Install safety barriers and display a danger sign.
- During the tests, it is strictly forbidden for anyone to touch the device, the chassis, or the conductors while voltage is applied.
- Before turning on power to this equipment, check that all connections are made with the correct tightening torque and the device is off (open position).
- Before turning on power to this equipment, put all devices, doors, and covers back in place.
- Before turning on power to this equipment, beware of potential hazards and carefully inspect the work area for tools and objects that may have been left inside the equipment.

Failure to follow these instructions will result in death or serious injury.

Procedure Definition



Procedure characteristics	Description
Action	Check that the device trips on ground-fault (MicroLogic Active 6.0) by using the MicroLogic Active display screen Maintenance menu.
Goal	Verify that the ground-fault protection operates.
Frequency	Refer to Recommended Frequency for the Routine End-User Maintenance Program, page 14.
Special indications	Connect the MicroLogic Active control unit to a power supply. For example, connect the Mobile Power Pack external battery to the MicroLogic USB port. A PIN code is required for this procedure.
Necessary tools	–
Related documents, page 6	<ul style="list-style-type: none"> • <i>MasterPacT MTZ1 IEC Circuit Breakers with MicroLogic Active Control Unit - User Guide</i> • <i>MasterPacT MTZ2/MTZ3 IEC Circuit Breakers with MicroLogic Active Control Unit - User Guide</i> • <i>MasterPacT MTZ - MicroLogic Active Control Unit - User Guide</i>

Preliminary Conditions

The device must comply with the conditions specified below. Refer to the *MasterPacT MTZ User Guides* to find instructions for operating the device.

Device installation type	Position of poles	Mechanism	Device position in the chassis
Fixed	Closed	Discharged	N/A
Drawout	Closed	Discharged	Test

Checking MicroLogic Active Control Unit Ground-Fault Protection

Step	Action	Corrective action
1	If the device is equipped with an MN undervoltage release, either connect it to the power supply with its rated voltage or remove the MN undervoltage release.	
2	The ground-fault protection test is available on the MicroLogic Active display screen, from the tree navigation menu, at Maintenance .	
3	Select Maintenance > Ground Protection Test .	
4	Enter the PIN code if a SecurityAdmin account has been created, or create a SecurityAdmin account.	
5	Press OK to confirm the PIN code. The ground-fault protection test confirmation menu opens.	
6	Press OK to confirm you want to start the ground-fault protection test and trip the circuit breaker.	
7	After a 5 s countdown, the Ig test trip pop-up trip message appears.	
8	Check that the G trip cause LED is blinking red and the Ig test trip pop-up trip message is displayed on a red screen: 	If the G trip cause LED does not blink, or the Ig test trip pop-up trip message is not displayed, contact your Schneider Electric Services representative.
9	Check that the device trips and that the blue fault-trip reset button on the front cover pops out.	<ul style="list-style-type: none"> If the blue fault-trip reset button does not pop out, contact your Schneider Electric Services representative. If the device does not trip: <ol style="list-style-type: none"> Check that the device is closed. Check that the blue fault-trip reset button is pushed-in. Refer to troubleshooting in the appendix, page 155. Do the procedure again. If the problem persists, contact your Schneider Electric Services representative.
10	Press OK to close the pop-up trip message.	
11	Press and hold the  button for more than 3 seconds to reset the trip cause LEDs.	

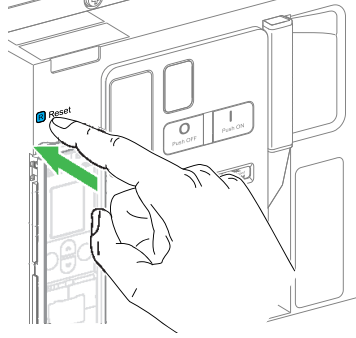
Step	Action	Corrective action
12	<p>Manually charge the mechanism by pulling the spring charging handle down seven times.</p> <p>When the spring charging handle no longer resists, the mechanism is charged.</p>	
13	<p>If the device is equipped with an MN undervoltage release, either connect it to the power supply with its rated voltage or remove the MN undervoltage release.</p>	
14	<p>Press the closing pushbutton.</p> <p>The device must not close.</p>	<p>If the device closes, check with customer order form:</p> <ul style="list-style-type: none"> • With RAR automatic reset option ordered by customer: operation is normal. • Without RAR automatic reset option ordered by customer: contact your Schneider Electric Services representative.
15	<p>Press the blue fault-trip reset button on the front cover to reset.</p> 	<p>If the blue fault-trip reset button does not reset, contact your Schneider Electric Services representative.</p>
16	<p>Press the closing pushbutton.</p> <p>The device closes.</p>	<p>If the device does not close, refer to troubleshooting in the appendix, page 155.</p> <p>If the problem persists, contact your Schneider Electric Services representative.</p>

Control Unit NII_ZA_3: Check Operation of Energy Reduction Maintenance Settings (ERMS)

Safety Instructions

⚠ ⚠ DANGER

HAZARD OF ELECTRIC SHOCK, EXPLOSION, OR ARC FLASH

- Apply appropriate personal protective equipment (PPE) and follow safe electrical work practices. See NFPA 70E, CSA Z462, NOM 029-STPS, or local equivalent.
- This equipment must only be installed and serviced by qualified electrical personnel.
- Unless specified otherwise in the maintenance procedures, all operations (inspection, test, and preventive maintenance) must be carried out with the device, the chassis, and the auxiliary circuits de-energized.
- Check that the device and the chassis are de-energized on the upstream and downstream terminals.
- Always use a properly rated voltage sensing device to confirm that the device, the chassis, and the auxiliary circuits are de-energized.
- Install safety barriers and display a danger sign.
- During the tests, it is strictly forbidden for anyone to touch the device, the chassis, or the conductors while voltage is applied.
- Before turning on power to this equipment, check that all connections are made with the correct tightening torque and the device is off (open position).
- Before turning on power to this equipment, put all devices, doors, and covers back in place.
- Before turning on power to this equipment, beware of potential hazards and carefully inspect the work area for tools and objects that may have been left inside the equipment.

Failure to follow these instructions will result in death or serious injury.

Procedure Definition

Procedure characteristics	Description
Action	<ul style="list-style-type: none"> Check engagement of the ERMS function by MicroLogic Active control unit ERMS button. Test the ERMS tripping curve.
Goal	Verify that the ERMS function is operational when engaged.
Frequency	Refer to Recommended Frequency for the Routine End-User Maintenance Program, page 14.
Special indications	–
Necessary tools	<ul style="list-style-type: none"> A PC running EcoStruxure Power Commission software. A USB-A to USB-C cable (RS PRO, reference: 251-3298)
Related documents, page 6	<ul style="list-style-type: none"> <i>MasterPacT MTZ1 IEC Circuit Breakers with MicroLogic Active Control Unit - User Guide</i> <i>MasterPacT MTZ2/MTZ3 IEC Circuit Breakers with MicroLogic Active Control Unit - User Guide</i> <i>MasterPacT MTZ - MicroLogic Active Control Unit - User Guide</i> <i>EcoStruxure Power Commission Online Help</i>

Preliminary Conditions

The device must comply with the conditions specified below. Refer to the *MasterPacT MTZ User Guides* to find instructions for operating the device.

Device installation type	Position of poles	Mechanism	Device position in the chassis
Fixed	Closed	Discharged	N/A
Drawout	Closed	Discharged	Test

Checking Engagement of ERMS by the MicroLogic Active ERMS Button

Step	Action	Corrective action
1	Open the MicroLogic Active control unit plastic cover and use a flat screwdriver to lift the ERMS flap  .	
2	Engage the ERMS function by pressing the MicroLogic Active control unit ERMS button.	
3	<p>On the MicroLogic Active control unit, check that:</p> <ol style="list-style-type: none"> 1. The ERMS LED is lit in blue. 2. The LSIG home screen is blue. 3. The Quick View screens are blue. 4. The Trip Curve screen within Quick View displays the message ERMS protection LSIG settings. <p>NOTE: An active medium or high severity event message overrides the blue screen, and is displayed in orange or red. Click OK to acknowledge. The LSIG home screen and Quick View screens are once again blue while ERMS is engaged.</p>	<ul style="list-style-type: none"> • If the ERMS LED is not lit blue, contact your Schneider Electric Services representative. • If the LSIG home screen is not blue: <ol style="list-style-type: none"> 1. Check the power supply connections to the control unit. 2. If the connection is OK, replace the MicroLogic Active control unit. • If the Quick View screens are not blue, contact your Schneider Electric Services representative. • If the Trip Curve screen within Quick View does not display the message ERMS protection LSIG settings, contact your Schneider Electric Services representative.

Testing the ERMS Tripping Curve

After engaging ERMS, follow this procedure to test the ERMS tripping curve.

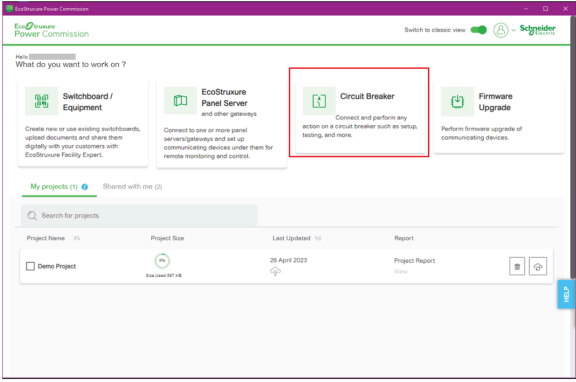
Step	Action	Corrective action
1	<p>Connect a PC running EcoStruxure Power Commission software to the MicroLogic Active control unit.</p>  <p>A Cable plug connected to the USB-C port of MicroLogic Active control unit B USB-A to USB-C port cable C PC running EcoStruxure Power Commission software</p>	
2	Launch EcoStruxure Power Commission software.	
3	<p>From the EcoStruxure Power Commission home page, click the Circuit Breaker section.</p> 	<p>If EcoStruxure Power Commission software does not connect to the MicroLogic Active control unit:</p> <ol style="list-style-type: none"> 1. Replace the USB cable. 2. Connect the PC to the MicroLogic Active control unit again. 3. If the problem persists, contact your Schneider Electric Services representative. <p>It disappears automatically when the device is discovered.</p>
4	<p>Click CONNECT on the displayed pop-up screen, to add the device to the switchboard and connect to it.</p> <p>Result: A window displays to indicate that device connection is in progress. It disappears automatically when the device is connected.</p>	
5	Enter the account details when prompted.	
6	Click the Automatic Trip Curve Test section.	

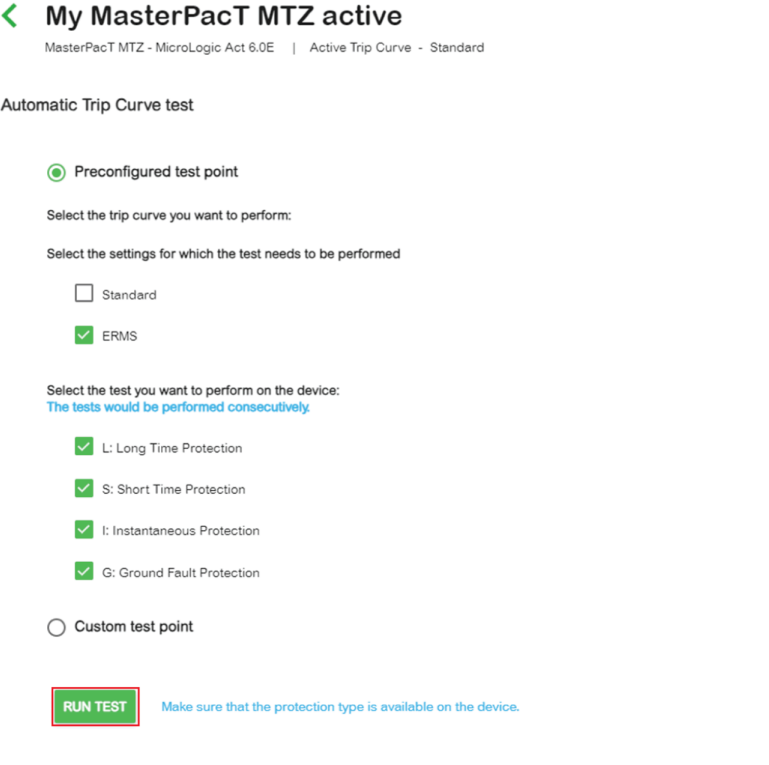
Step	Action	Corrective action
7	<p>Launch a trip test sequence on the ERMS settings:</p> <ol style="list-style-type: none"> 1. Select ERMS. 2. Select the tests to run. 3. Click the RUN TEST button and follow the prompts.  <p>Result: The protection trips on the ERMS settings.</p>	<p>If the trip test fails, contact your Schneider Electric Services representative.</p>
8	<p>Disengage the ERMS function by pressing the MicroLogic Active control unit ERMS button.</p>	
9	<p>On the MicroLogic Active control unit, check that:</p> <ol style="list-style-type: none"> 1. The ERMS LED is off. 2. The LSIG home screen has a black background. 3. The Quick View screens have a black background. 4. The Trip Curve screen within Quick View displays the message Standard Protection LSIG settings. 	

Device Locking NII_ZA_1: Operate Device Keylocks

Safety Instructions

⚠️⚠️ DANGER

HAZARD OF ELECTRIC SHOCK, EXPLOSION, OR ARC FLASH

- Apply appropriate personal protective equipment (PPE) and follow safe electrical work practices. See NFPA 70E, CSA Z462, NOM 029-STPS, or local equivalent.
- This equipment must only be installed and serviced by qualified electrical personnel.
- Unless specified otherwise in the maintenance procedures, all operations (inspection, test, and preventive maintenance) must be carried out with the device, the chassis, and the auxiliary circuits de-energized.
- Check that the device and the chassis are de-energized on the upstream and downstream terminals.
- Always use a properly rated voltage sensing device to confirm that the device, the chassis, and the auxiliary circuits are de-energized.
- Install safety barriers and display a danger sign.
- During the tests, it is strictly forbidden for anyone to touch the device, the chassis, or the conductors while voltage is applied.
- Before turning on power to this equipment, check that all connections are made with the correct tightening torque and the device is off (open position).
- Before turning on power to this equipment, put all devices, doors, and covers back in place.
- Before turning on power to this equipment, beware of potential hazards and carefully inspect the work area for tools and objects that may have been left inside the equipment.

Failure to follow these instructions will result in death or serious injury.

Procedure Definition

Procedure characteristics	Description
Action	Check the locking and unlocking of the device with keylocks.
Goal	Verify the operation of keylocks with the optional VSPO OFF-position locking accessory.
Frequency	Refer to Recommended Frequency for the Routine End-User Maintenance Program, page 14.
Special indications	–
Necessary tools	–
Related documents, page 6	<ul style="list-style-type: none"> • <i>MasterPacT MTZ1 IEC Circuit Breakers with MicroLogic Active Control Unit - User Guide</i> • <i>MasterPacT MTZ2/MTZ3 IEC Circuit Breakers with MicroLogic Active Control Unit - User Guide</i> • <i>MasterPacT MTZ1 - VCPO OFF-Position Locking and BPFE Support - Instruction Sheet</i> • <i>MasterPacT MTZ2/MTZ3 - VCPO OFF-Position Locking and BPFE Support - Instruction Sheet</i>

Preliminary Conditions

The device must comply with the conditions specified below. Refer to the *MasterPacT MTZ User Guides* to find instructions for operating the device.

Device installation type	Position of poles	Mechanism	Device position in the chassis
Fixed	Closed	Discharged	N/A
Drawout	Open	Discharged	Disconnected

Checking Locking the Device in the Open Position

For devices with two keylocks, execute the following procedure for each keylock. Locking with one key is sufficient to lock the device in the open position.

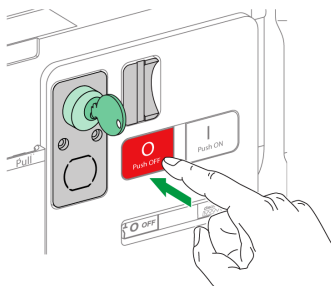
Step	Action	Corrective action
1	With the key captive in the keylock, check that the device is not locked.	If the key is missing or broken, replace the keylock. Refer to the <i>MasterPacT MTZ Catalog</i> for spare parts.
2	Press the opening pushbutton to open the device. 	
3	<ul style="list-style-type: none"> For MasterPacT MTZ1: Press and hold down the opening pushbutton, and simultaneously turn the key counterclockwise. For MasterPacT MTZ2/MTZ3: Turn the key counterclockwise. 	If the key does not turn, replace the keylock.
4	Remove the key and release the opening pushbutton. NOTE: For MasterPacT MTZ1, the pushbutton remains pushed-in.	
5	Charge the mechanism to be able to give a closing order.	
6	If the device is equipped with an MN undervoltage release, either connect it to the power supply with its rated voltage or remove the MN undervoltage release.	

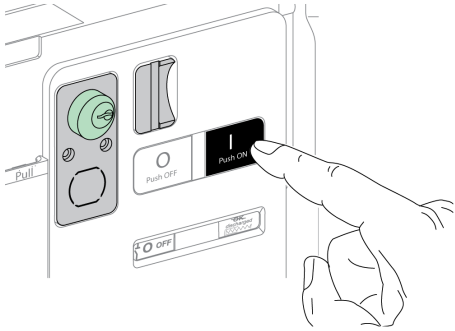
Step	Action	Corrective action
7	<p>Press the closing pushbutton.</p>  <p>The device must not close.</p>	<ul style="list-style-type: none"> • If the device closes, check that the lock support is correctly installed (refer to <i>MasterPacT MTZ - VCPO OFF-Position Locking and BPFE Support - Instruction Sheet</i>). Then do the procedure again. • If the lock support is damaged, replace it. • If the keylock is corroded, replace it. <p>If the problem persists, contact your Schneider Electric Services representative.</p>
8	<p>If there is a second key, unlock the device and do the procedure with the second key.</p>	

Checking Device Unlocking

Before starting this check, verify that the device is locked in the open position.

For devices with two keylocks, execute the following procedure for each keylock. Both keys must be inserted in the keylocks to unlock the device.

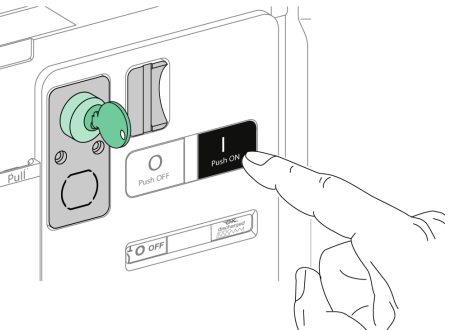
Step	Action	Corrective action
1	<p>Put the key in the keylock.</p>	
2	<p>Turn the key clockwise and check that the key cannot be removed from the lock.</p>	<p>If the key does not turn or can be removed, replace the keylock.</p> <p>Refer to the <i>MasterPacT MTZ Catalog</i> for spare parts.</p>
3	<p>Press the closing pushbutton to close the device.</p>  <p>The device closes.</p>	<p>If the device does not close, check that the lock support is correctly installed (refer to <i>MasterPacT MTZ - VCPO OFF-Position Locking and BPFE Support - Instruction Sheet</i>). Then do the procedure again.</p> <p>If the lock support is damaged, replace it.</p> <p>If the keylock is corroded, replace it.</p> <p>If the problem persists, contact your Schneider Electric Services representative.</p>
4	<p>With the device closed, check that the key remains captive unless the opening pushbutton is pressed.</p>	

Device Locking NII_ZA_2: Operate Device Padlocks

Safety Instructions

 **DANGER**

HAZARD OF ELECTRIC SHOCK, EXPLOSION, OR ARC FLASH

- Apply appropriate personal protective equipment (PPE) and follow safe electrical work practices. See NFPA 70E, CSA Z462, NOM 029-STPS, or local equivalent.
- This equipment must only be installed and serviced by qualified electrical personnel.
- Unless specified otherwise in the maintenance procedures, all operations (inspection, test, and preventive maintenance) must be carried out with the device, the chassis, and the auxiliary circuits de-energized.
- Check that the device and the chassis are de-energized on the upstream and downstream terminals.
- Always use a properly rated voltage sensing device to confirm that the device, the chassis, and the auxiliary circuits are de-energized.
- Install safety barriers and display a danger sign.
- During the tests, it is strictly forbidden for anyone to touch the device, the chassis, or the conductors while voltage is applied.
- Before turning on power to this equipment, check that all connections are made with the correct tightening torque and the device is off (open position).
- Before turning on power to this equipment, put all devices, doors, and covers back in place.
- Before turning on power to this equipment, beware of potential hazards and carefully inspect the work area for tools and objects that may have been left inside the equipment.

Failure to follow these instructions will result in death or serious injury.

Procedure Definition

Procedure characteristics	Description
Action	Check the locking and unlocking of the device with padlocks.
Goal	Verify the operation of padlocks with the optional VCPO OFF-position locking accessory.
Frequency	Refer to Recommended Frequency for the Routine End-User Maintenance Program, page 14.
Special indications	–
Necessary tools	Padlock with shackle diameter 5–8 mm
Related documents, page 6	<ul style="list-style-type: none"> • <i>MasterPacT MTZ1 IEC Circuit Breakers with MicroLogic Active Control Unit - User Guide</i> • <i>MasterPacT MTZ2/MTZ3 IEC Circuit Breakers with MicroLogic Active Control Unit - User Guide</i> • <i>MasterPacT MTZ1 - VCPO OFF-Position Locking and BPFE Support - Instruction Sheet</i> • <i>MasterPacT MTZ2/MTZ3 - VCPO OFF-Position Locking and BPFE Support - Instruction Sheet</i>

Preliminary Conditions

The device must comply with the conditions specified below. Refer to the *MasterPacT MTZ User Guides* to find instructions for operating the device.

Device installation type	Position of poles	Mechanism	Device position in the chassis
Fixed	Open	Discharged	N/A
Drawout	Open	Discharged	Disconnected

Checking Locking the Device in the Open Position

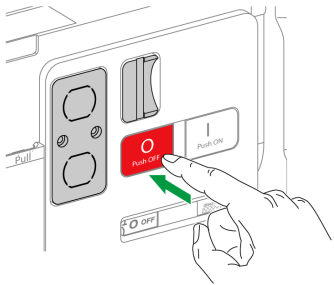
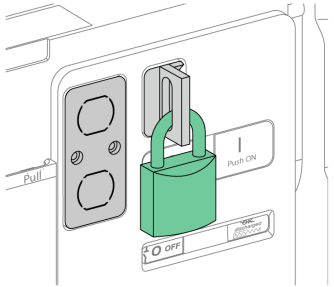
Step	Action	Corrective action
1	<p>Press the opening pushbutton to open the device.</p> 	
2	<p>Pull out the tab of the OFF-position locking accessory.</p>	<p>If the padlocking tab cannot be pulled out, check that the lock support is correctly installed (refer to <i>MasterPacT MTZ - VCPO OFF-Position Locking and BFFE Support - Instruction Sheet</i>). Then do the procedure again.</p> <p>If the lock support is damaged, replace it.</p> <p>Refer to the <i>MasterPacT MTZ Catalog</i> for spare parts.</p>
3	<p>Install the padlock.</p> 	
4	<p>Charge the mechanism to be able to give a closing order.</p>	

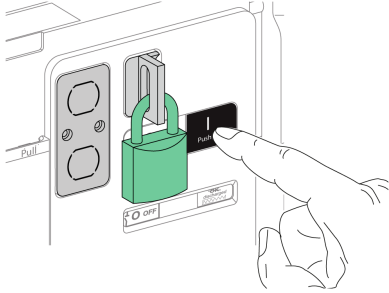
Step	Action	Corrective action
5	If the device is equipped with an MN undervoltage release, either connect it to the power supply with its rated voltage or remove the MN undervoltage release.	
6	<p>Press the closing pushbutton.</p>  <p>The device must not close.</p>	<p>If the device closes, check that the lock support is correctly installed (refer to <i>MasterPacT MTZ - VCPO OFF-Position Locking and BPFE Support - Instruction Sheet</i>). Then do the procedure again.</p> <p>If the lock support is damaged, replace it.</p> <p>If the problem persists, contact your Schneider Electric Services representative.</p>

Checking Device Unlocking

Before starting this check, verify that the device is padlocked in the open position.

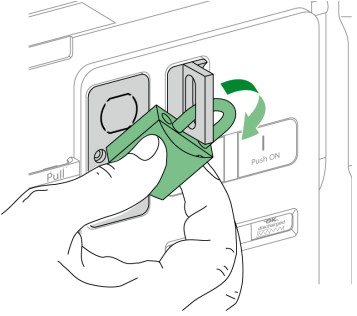
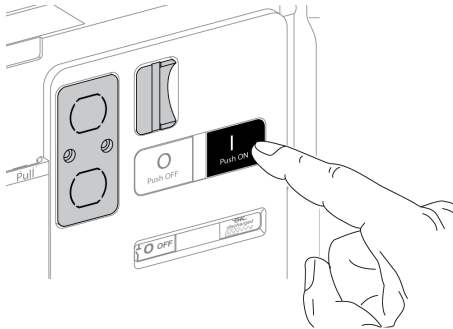
Step	Action	Corrective action
1	<p>Remove the padlock from the padlocking tab.</p>  <ul style="list-style-type: none"> For MasterPacT MTZ1: push in the tab. For MasterPacT MTZ2/MTZ3: the tab retracts automatically. 	<p>If the tab does not retract fully, replace the lock support.</p>
2	<p>Press the closing pushbutton to close the device.</p>  <p>The device closes.</p>	<p>If the device does not close, check that the lock support is correctly installed (refer to <i>MasterPacT MTZ - VCPO OFF-Position Locking and BPFE Support - Instruction Sheet</i>). Then do the procedure again.</p> <p>If the lock support is damaged, replace it.</p> <p>If the problem persists, contact your Schneider Electric Services representative.</p>
3	With the device closed, check that the padlocking tab cannot be pulled out.	If the tab can be pulled out, replace the lock support.

Chassis NII_ZA_1: Check Device Racking Operation

Safety Instructions

 **DANGER**

HAZARD OF ELECTRIC SHOCK, EXPLOSION, OR ARC FLASH

- Apply appropriate personal protective equipment (PPE) and follow safe electrical work practices. See NFPA 70E, CSA Z462, NOM 029-STPS, or local equivalent.
- This equipment must only be installed and serviced by qualified electrical personnel.
- Unless specified otherwise in the maintenance procedures, all operations (inspection, test, and preventive maintenance) must be carried out with the device, the chassis, and the auxiliary circuits de-energized.
- Check that the device and the chassis are de-energized on the upstream and downstream terminals.
- Always use a properly rated voltage sensing device to confirm that the device, the chassis, and the auxiliary circuits are de-energized.
- Install safety barriers and display a danger sign.
- During the tests, it is strictly forbidden for anyone to touch the device, the chassis, or the conductors while voltage is applied.
- Before turning on power to this equipment, check that all connections are made with the correct tightening torque and the device is off (open position).
- Before turning on power to this equipment, put all devices, doors, and covers back in place.
- Before turning on power to this equipment, beware of potential hazards and carefully inspect the work area for tools and objects that may have been left inside the equipment.

Failure to follow these instructions will result in death or serious injury.

Procedure Definition

Procedure characteristics	Description
Action	<ul style="list-style-type: none"> • Check the racking operations of the device. • Check the device pre-tripping. • Check the chassis position indicator.
Goal	Verify that the device operates correctly in its chassis.
Frequency	Refer to Recommended Frequency for the Routine End-User Maintenance Program, page 14.
Special indications	Before the check, the device must be de-energized (no current flowing through the device and no voltage present on busbar).
Necessary tools	Racking handle
Related documents, page 6	<ul style="list-style-type: none"> • <i>MasterPacT MTZ1 IEC Circuit Breakers with MicroLogic Active Control Unit - User Guide</i> • <i>MasterPacT MTZ2/MTZ3 IEC Circuit Breakers with MicroLogic Active Control Unit - User Guide</i>

Preliminary Conditions

The device must comply with the conditions specified below. Refer to the *MasterPacT MTZ User Guides* to find instructions for operating the device.

Device installation type	Position of poles	Mechanism	Device position in the chassis
Fixed	N/A	N/A	N/A
Drawout	Closed	Charged	Connected

Racking Handle Insertion Possibilities

Before starting the check, verify that the racking handle can be inserted into its socket:

- The device is not locked with keylocks or padlocks.
- If the IBPO racking interlock between the racking handle and the opening pushbutton is installed (MasterPacT MTZ2/MTZ3), press the opening pushbutton to allow insertion of the racking handle, page 66.
- With VPOC racking interlock option installed, the switchboard door must be closed.

MasterPacT MTZ1

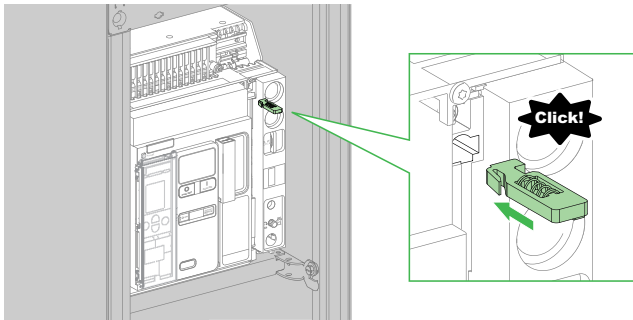

MasterPacT MTZ2/MTZ3

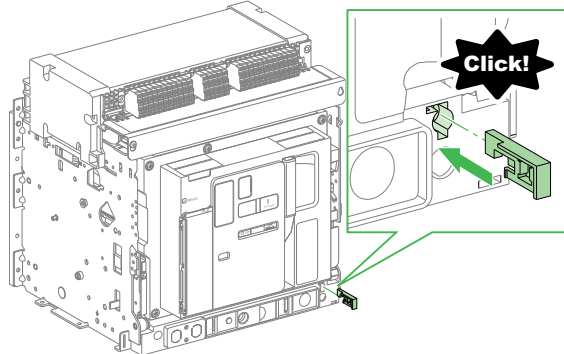



The following table shows the possible ways that the racking handle can be inserted.

Switchboard door	VPOC option	Racking handle insertion
Closed	Absent	Possible
	Present	Possible
Open	Absent	Possible
	Present	Not possible ⁽¹⁾

(1) Press and hold the racking interlock to insert the racking handle into the racking handle socket.

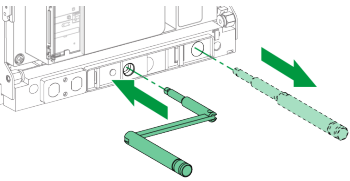
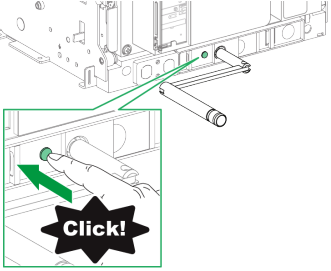
Racking-out the Device from Connected to Disconnected Position

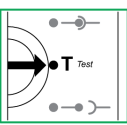
Step	Action	Corrective action
1	<p>With the drawout device in the chassis, check that the indicators located on the front of the chassis show that the device is closed and in the connected position.</p> 	<p>If the position indicator is incorrect, contact your Schneider Electric Services representative.</p>
2	<p>Remove the racking handle from its storage space, and then insert it into the racking handle socket.</p> 	<p>If the racking handle cannot be inserted into the racking handle socket, check the insertion possibilities above.</p> <p>If the problem persists, contact your Schneider Electric Services representative.</p>
3	<p>Push in the position release button.</p> 	
4	<p>Turn the racking handle counterclockwise:</p> <ul style="list-style-type: none"> MasterPacT MTZ1: one turn. MasterPacT MTZ2/MTZ3: three to four turns. <p>NOTE: The racking handle cannot be turned if the position release button is not pushed in.</p>	<p>If the racking handle cannot be turned, contact your Schneider Electric Services representative.</p>
5	<p>The device opens automatically.</p> <p>Check that the position indicator indicates that the device is in open position.</p> 	<p>If the device does not open or the position indicator is incorrect, contact your Schneider Electric Services representative.</p>
6	<p>Continue turning the racking handle counterclockwise until the test position is reached.</p> <p>When the test position is reached, the mechanism blocks the racking handle and the position release button pops out.</p>	<p>If the mechanism is not blocked in the test position or the button does not pop out, contact your Schneider Electric Services representative.</p>
7	<p>Check that the position indicator indicates the test position.</p> 	<p>If the indicator is incorrect, contact your Schneider Electric Services representative.</p>
8	<p>Push in the position release button again.</p>	
9	<p>Turn the racking handle counterclockwise until the disconnected position is reached.</p> <p>NOTE: The racking handle cannot be turned if the position release button is not pushed in.</p>	<p>If the racking handle cannot be turned, contact your Schneider Electric Services representative.</p>
10	<p>When the disconnected position is reached, the mechanism blocks the racking handle and the position release button pops out.</p>	<p>If the mechanism is not blocked in the disconnected position or the button does not pop out</p>

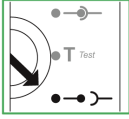
Step	Action	Corrective action
		out again, contact your Schneider Electric Services representative
11	Check that the position indicator indicates the disconnected position. 	If the indicator is incorrect, contact your Schneider Electric Services representative.
12	Remove the racking handle from the racking socket, and then put it back into its storage space.	
13	Open the door of the switchboard.	

Racking-in the Device from Disconnected to Connected Position

Before starting this check, verify that the device is open and the mechanism is charged.

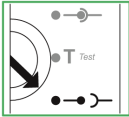
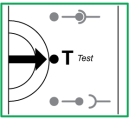
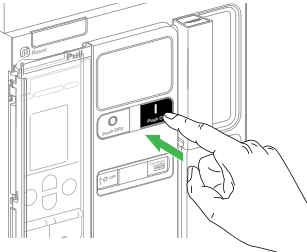
Step	Action	Corrective action
1	Check that the position indicator located on the front of the chassis indicates the disconnected position. 	If the position indicator is incorrect, contact your Schneider Electric Services representative.
2	Remove the racking handle from its storage space, and then insert it into the racking handle socket. NOTE: If the IBPO racking interlock between the racking handle and the opening pushbutton is installed (MasterPacT MTZ2/MTZ3), press the opening pushbutton to allow insertion of the racking handle.	If the racking handle cannot be inserted into the racking handle socket, check the insertion possibilities above. If the problem persists, contact your Schneider Electric Services representative.
3	Push in the position release button.	
4	Turn the racking handle clockwise until the test position is reached. NOTE: The racking handle cannot be turned if the position release button is not pushed in.	
5	When the test position is reached, the mechanism blocks the racking handle and the position release button pops out.	If the mechanism is not blocked in the test position or the button does not pop out, contact your Schneider Electric Services representative.
6	Check that the position indicator indicates the test position. 	If the position indicator is incorrect, contact your Schneider Electric Services representative.
7	Press the closing pushbutton to close the device.  The device closes.	If the device does not close, check that: <ul style="list-style-type: none"> • MN undervoltage release is connected to a power supply. • The device is charged. If the problem persists, contact your Schneider Electric Services representative.

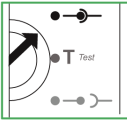
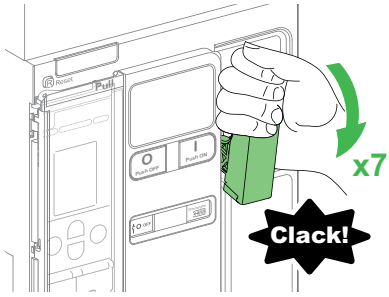
Step	Action	Corrective action
8	Push in the position release button again.	
9	Turn the racking handle clockwise: <ul style="list-style-type: none"> • MasterPacT MTZ1: one turn. • MasterPacT MTZ2/MTZ3: six to seven turns. NOTE: The racking handle cannot be turned if the position release button is not pushed in.	
10	The device opens automatically.	If the device does not open, contact your Schneider Electric Services representative.
11	Continue turning the racking handle clockwise until the connected position is reached. When the connected position is reached, the mechanism blocks the racking handle and the position release button pops out.	If the mechanism is not blocked in the connected position or the button does not pop out, contact your Schneider Electric Services representative.
12	Check that the position indicator indicates the connected position. 	If the position indicator is incorrect, contact your Schneider Electric Services representative.
13	Remove the racking handle from the racking socket, and then put it back into its storage space.	
14	Charge the spring mechanism. 	
15	Close the device.	If the device does not close, check that: <ul style="list-style-type: none"> • MN undervoltage release is connected to a power supply. • The device is charged. If the problem persists, contact your Schneider Electric Services representative.

Chassis NII_ZA_2: Check IBPO Racking Interlock (MasterPacT MTZ2/MTZ3)

Safety Instructions

⚡ ⚠ DANGER

HAZARD OF ELECTRIC SHOCK, EXPLOSION, OR ARC FLASH

- Apply appropriate personal protective equipment (PPE) and follow safe electrical work practices. See NFPA 70E, CSA Z462, NOM 029-STPS, or local equivalent.
- This equipment must only be installed and serviced by qualified electrical personnel.
- Unless specified otherwise in the maintenance procedures, all operations (inspection, test, and preventive maintenance) must be carried out with the device, the chassis, and the auxiliary circuits de-energized.
- Check that the device and the chassis are de-energized on the upstream and downstream terminals.
- Always use a properly rated voltage sensing device to confirm that the device, the chassis, and the auxiliary circuits are de-energized.
- Install safety barriers and display a danger sign.
- During the tests, it is strictly forbidden for anyone to touch the device, the chassis, or the conductors while voltage is applied.
- Before turning on power to this equipment, check that all connections are made with the correct tightening torque and the device is off (open position).
- Before turning on power to this equipment, put all devices, doors, and covers back in place.
- Before turning on power to this equipment, beware of potential hazards and carefully inspect the work area for tools and objects that may have been left inside the equipment.

Failure to follow these instructions will result in death or serious injury.

Procedure Definition

Procedure characteristics	Description
Action	Check IBPO racking interlock between racking handle and opening pushbutton. Check disconnection and connection of a drawout MasterPacT MTZ2/MTZ3 device when the IBPO racking interlock is installed.
Goal	Verify that the IBPO racking interlock operates correctly and does not allow connection and disconnection of the device without additional action.
Frequency	Refer to Recommended Frequency for the Routine End-User Maintenance Program, page 14.
Special indications	–
Necessary tools	Racking handle
Related documents, page 6	<i>MasterPacT MTZ2/MTZ3 IEC Circuit Breakers with MicroLogic Active Control Unit - User Guide</i>

Preliminary Conditions

The device must comply with the conditions specified below. Refer to the *MasterPacT MTZ User Guides* to find instructions for operating the device.

Device installation type	Position of poles	Mechanism	Device position in the chassis
Fixed	N/A	N/A	N/A
Drawout	Open	Charged	Connected

Checking Device Disconnection with IBPO Racking Interlock Accessory (MasterPacT MTZ2/MTZ3)

Step	Action	Corrective action
1	Check that the equipment door is closed.	
2	Check that the racking handle cannot be inserted into the racking handle socket.	
3	Press and hold the opening pushbutton to allow insertion of the racking handle into the racking handle socket.	<p>If the racking handle cannot be inserted into the racking handle socket:</p> <ol style="list-style-type: none"> 1. Open the equipment door. 2. Check if the VPOC racking interlock option is present. 3. Remove the VPOC racking interlock, if necessary. <p>If the problem persists, contact your Schneider Electric Services representative.</p>
4	<p>Rack-out the device from connected to test position.</p> <p>When the test position is reached, the mechanism blocks the racking handle and the position release button pops out.</p> <p>NOTE: If needed, refer to device racking operations as per procedure Chassis NII_ZA_1, page 61.</p>	
5	Remove the racking handle from the racking handle socket.	

Checking Device Connection with IBPO Racking Interlock Accessory (MasterPacT MTZ2/MTZ3)

Step	Action	Corrective action
1	Check that the racking handle cannot be inserted into the racking handle socket.	
2	Press and hold the opening pushbutton to allow insertion of the racking handle into the racking handle socket.	
3	<p>Rack-in the device from test to connected position.</p> <p>When the connected position is reached, the mechanism blocks the racking handle and the position release button pops out.</p> <p>NOTE: If needed, refer to device racking operations as per procedure Chassis NII_ZA_1, page 61.</p>	
4	Remove the racking handle from the racking handle socket, and then put it back into its storage space.	
5	Reinstall the VPOC racking interlock if removed previously.	

Chassis Locking NII_ZA_1: Operate Chassis Keylocking System

Safety Instructions

⚡ ⚠ DANGER

HAZARD OF ELECTRIC SHOCK, EXPLOSION, OR ARC FLASH

- Apply appropriate personal protective equipment (PPE) and follow safe electrical work practices. See NFPA 70E, CSA Z462, NOM 029-STPS, or local equivalent.
- This equipment must only be installed and serviced by qualified electrical personnel.
- Unless specified otherwise in the maintenance procedures, all operations (inspection, test, and preventive maintenance) must be carried out with the device, the chassis, and the auxiliary circuits de-energized.
- Check that the device and the chassis are de-energized on the upstream and downstream terminals.
- Always use a properly rated voltage sensing device to confirm that the device, the chassis, and the auxiliary circuits are de-energized.
- Install safety barriers and display a danger sign.
- During the tests, it is strictly forbidden for anyone to touch the device, the chassis, or the conductors while voltage is applied.
- Before turning on power to this equipment, check that all connections are made with the correct tightening torque and the device is off (open position).
- Before turning on power to this equipment, put all devices, doors, and covers back in place.
- Before turning on power to this equipment, beware of potential hazards and carefully inspect the work area for tools and objects that may have been left inside the equipment.

Failure to follow these instructions will result in death or serious injury.

Procedure Definition

Procedure characteristics	Description
Action	Check the locking and unlocking of the chassis with keylocks in the disconnected position or in any position, according to the chassis locking configuration.
Goal	Verify the chassis keylocking system with the optional VSPD chassis locking accessory correctly operates.
Frequency	Refer to Recommended Frequency for the Routine End-User Maintenance Program, page 14.
Special indications	–
Necessary tools	Racking handle
Related documents, page 6	<ul style="list-style-type: none"> • <i>MasterPacT MTZ1 IEC Circuit Breakers with MicroLogic Active Control Unit - User Guide</i> • <i>MasterPacT MTZ2/MTZ3 IEC Circuit Breakers with MicroLogic Active Control Unit - User Guide</i> • <i>MasterPacT MTZ1 - VSPD Disconnected Position Locking - Instruction Sheet</i> • <i>MasterPacT MTZ2/MTZ3 - VSPD Disconnected Position Locking - Instruction Sheet</i>

Preliminary Conditions

The device must comply with the conditions specified below. Refer to the *MasterPacT MTZ User Guides* to find instructions for operating the device.

Device installation type	Position of poles	Mechanism	Device position in the chassis
Fixed	N/A	N/A	N/A
Drawout	Open	Discharged	Disconnected

Determining the Chassis Locking Configuration

The MasterPacT MTZ drawout devices offer two chassis locking possibilities with keylocks:

- In the disconnected position.
- In any position (disconnected, test, or connected).

To determine the chassis locking possibility, move the device to the connected or test position:

- If you cannot pull out the padlocking tab, the chassis can be locked in the disconnected position only. Execute the locking procedure then the unlocking procedure.
- If you can pull out the padlocking tab, the chassis can be locked in the disconnected, test, or connected position. The locking and unlocking procedures are the same as with chassis in the disconnected position. Execute these procedures in each position: connected, test, disconnected.

The following table shows the chassis locking configurations.

Chassis locking system	Device position in the chassis	Padlocking tab	Racking handle insertion with chassis locked
Chassis locking in the disconnected position	Connected	Cannot be pulled out	Possible
	Test	Cannot be pulled out	Possible
	Disconnected	Can be pulled out	Not possible
Chassis locking in any position	Connected	Can be pulled out	Not possible
	Test	Can be pulled out	Not possible
	Disconnected	Can be pulled out	Not possible

Checking Chassis Locking with Device in the Disconnected Position

For chassis with two keylocks, execute the following procedure for each keylock. Locking with one key is sufficient to lock racking operations.

Step	Action	Corrective action
1	With the key captive in the keylock, check that the chassis is not locked.	If the key is missing or broken, replace the keylock. Refer to the <i>MasterPacT MTZ Catalog</i> for spare parts.
2	Verify that the racking handle is not inserted in the racking handle socket.	
3	Turn the key counterclockwise, and then remove it.	If the key does not turn, replace the keylock.

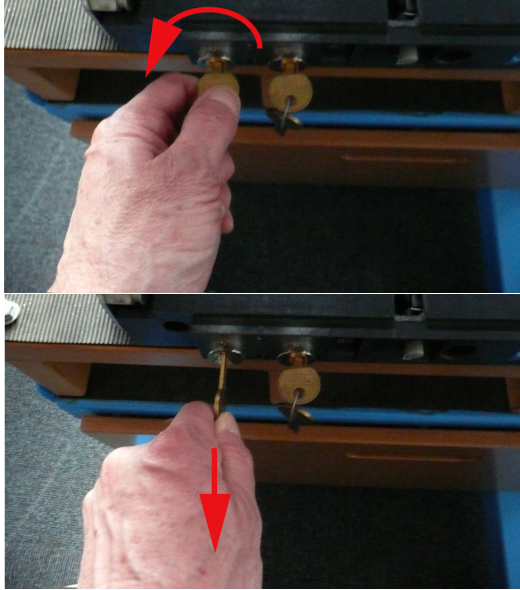
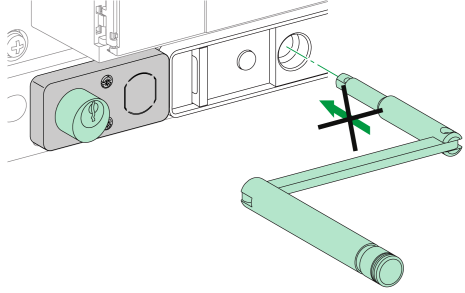
Step	Action	Corrective action
		
4	<p>Check that the racking handle cannot be inserted into the racking handle socket.</p> 	<p>If the racking handle can be inserted, check that the lock support is correctly installed (refer to <i>MasterPacT MTZ - VSPD Disconnected Position Locking - Instruction Sheet</i>).</p> <p>If the lock support is damaged, replace it.</p> <p>If the keylock is corroded, replace it.</p> <p>Then do the procedure again.</p> <p>If the problem persists, contact your Schneider Electric Services representative.</p>
5	<p>Unlock the chassis and remove the key. Then do the procedure with the second key, if any.</p>	

Checking Chassis Unlocking with Device in the Disconnected Position

Before starting this check, verify that the chassis is locked in the disconnected position.

For chassis with two keylocks, execute the following procedure for each keylock. Both keys must be inserted in the keylocks to unlock the chassis.

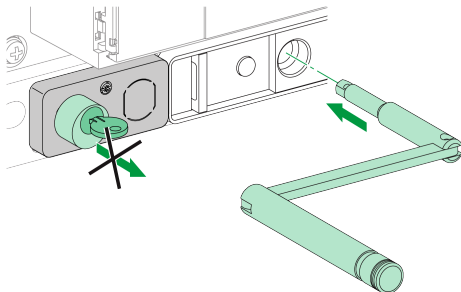
Step	Action	Corrective action
1	Put the key in the lock.	
2	Turn the key clockwise and check that the key remains captive.	<p>If the key does not turn, replace the keylock.</p> <p>Refer to the <i>MasterPacT MTZ Catalog</i> for spare parts.</p>
3	<p>Check that the racking handle can be inserted into the racking handle socket so that racking operations can be carried out.</p> 	<p>If the racking handle cannot be inserted, check that the lock support is correctly installed (refer to <i>MasterPacT MTZ - VSPD Disconnected Position Locking - Instruction Sheet</i>).</p> <p>If the lock support is damaged, replace it.</p> <p>If the keylock is corroded, replace it.</p> <p>Then do the procedure again.</p> <p>If the problem persists, contact your Schneider Electric Services representative.</p>

Chassis Locking NII_ZA_2: Operate Chassis Padlocking System

Safety Instructions

 **DANGER**

HAZARD OF ELECTRIC SHOCK, EXPLOSION, OR ARC FLASH

- Apply appropriate personal protective equipment (PPE) and follow safe electrical work practices. See NFPA 70E, CSA Z462, NOM 029-STPS, or local equivalent.
- This equipment must only be installed and serviced by qualified electrical personnel.
- Unless specified otherwise in the maintenance procedures, all operations (inspection, test, and preventive maintenance) must be carried out with the device, the chassis, and the auxiliary circuits de-energized.
- Check that the device and the chassis are de-energized on the upstream and downstream terminals.
- Always use a properly rated voltage sensing device to confirm that the device, the chassis, and the auxiliary circuits are de-energized.
- Install safety barriers and display a danger sign.
- During the tests, it is strictly forbidden for anyone to touch the device, the chassis, or the conductors while voltage is applied.
- Before turning on power to this equipment, check that all connections are made with the correct tightening torque and the device is off (open position).
- Before turning on power to this equipment, put all devices, doors, and covers back in place.
- Before turning on power to this equipment, beware of potential hazards and carefully inspect the work area for tools and objects that may have been left inside the equipment.

Failure to follow these instructions will result in death or serious injury.

Procedure Definition

Procedure characteristics	Description
Action	Check the locking and unlocking of the chassis with padlocks in disconnected position or in any position, according to the chassis locking configuration.
Goal	Verify that the chassis padlocking system correctly operates.
Frequency	Refer to Recommended Frequency for the Routine End-User Maintenance Program, page 14.
Special indications	–
Necessary tools	<ul style="list-style-type: none"> • Padlock with shackle diameter 5–8 mm • Racking handle
Related documents, page 6	<ul style="list-style-type: none"> • <i>MasterPacT MTZ1 IEC Circuit Breakers with MicroLogic Active Control Unit - User Guide</i> • <i>MasterPacT MTZ2/MTZ3 IEC Circuit Breakers with MicroLogic Active Control Unit - User Guide</i>

Preliminary Conditions

The device must comply with the conditions specified below. Refer to the *MasterPacT MTZ User Guides* to find instructions for operating the device.

Device installation type	Position of poles	Mechanism	Device position in the chassis
Fixed	N/A	N/A	N/A
Drawout	Open	Discharged	Disconnected

Determining the Chassis Locking Configuration

The MasterPacT MTZ drawout devices offer two chassis locking possibilities with padlocks:

- In disconnected position.
- In any position (disconnected, test, or connected).

To determine the chassis locking possibility, move the device to the connected or test position:

- If you cannot pull out the padlocking tab, the chassis can be locked in disconnected position only. Execute the locking procedure then the unlocking procedure.
- If you can pull out the padlocking tab, the chassis can be locked in disconnected, test, or connected position. The locking and unlocking procedures are the same as with chassis in disconnected position. Execute these procedures in each position: connected, test, disconnected.

The following table shows the chassis locking configurations.

Chassis locking system	Device position in the chassis	Padlocking tab	Racking handle insertion with chassis locked
Chassis locking in disconnected position	Connected	Cannot be pulled out	Possible
	Test	Cannot be pulled out	Possible
	Disconnected	Can be pulled out	Not possible
Chassis locking in any position	Connected	Can be pulled out	Not possible
	Test	Can be pulled out	Not possible
	Disconnected	Can be pulled out	Not possible

Checking Chassis Padlocking With Device in Disconnected Position

Step	Action	Corrective action
1	Verify that the racking handle is not inserted in the racking handle socket.	
2	Pull out the padlocking tab.	If the padlocking tab cannot be pulled out, contact your Schneider Electric Services representative.

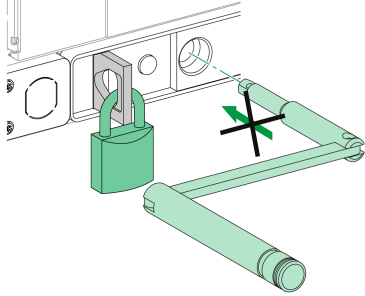
Step	Action	Corrective action
3	Insert the padlock in this tab.	
4	<p>Check that the racking handle cannot be inserted into the racking handle socket.</p> 	<p>If the racking handle can be inserted, contact your Schneider Electric Services representative.</p>

Checking Chassis Unlocking With Device in Disconnected Position

Before starting this check, verify that the chassis is locked in disconnected position.

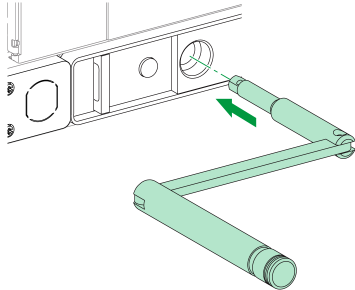
Step	Action	Corrective action
1	<p>Remove the padlock from the tab.</p> <ul style="list-style-type: none"> With MasterPacT MTZ1: push in the tab. With MasterPacT MTZ2/MTZ3: the tab retracts automatically. 	<p>If the tab does not retract fully, contact your Schneider Electric Services representative.</p>
2	<p>Check that the racking handle can be inserted into the racking handle socket so that racking operations can be carried out.</p> 	<p>If the racking handle cannot be inserted, contact your Schneider Electric Services representative.</p>

Mechanical Interlocking NII_ZA_1: Operate Interlocking Systems

Safety Instructions

⚠️⚠️ DANGER

HAZARD OF ELECTRIC SHOCK, EXPLOSION, OR ARC FLASH

- Apply appropriate personal protective equipment (PPE) and follow safe electrical work practices. See NFPA 70E, CSA Z462, NOM 029-STPS, or local equivalent.
- This equipment must only be installed and serviced by qualified electrical personnel.
- Unless specified otherwise in the maintenance procedures, all operations (inspection, test, and preventive maintenance) must be carried out with the device, the chassis, and the auxiliary circuits de-energized.
- Check that the device and the chassis are de-energized on the upstream and downstream terminals.
- Always use a properly rated voltage sensing device to confirm that the device, the chassis, and the auxiliary circuits are de-energized.
- Install safety barriers and display a danger sign.
- During the tests, it is strictly forbidden for anyone to touch the device, the chassis, or the conductors while voltage is applied.
- Before turning on power to this equipment, check that all connections are made with the correct tightening torque and the device is off (open position).
- Before turning on power to this equipment, put all devices, doors, and covers back in place.
- Before turning on power to this equipment, beware of potential hazards and carefully inspect the work area for tools and objects that may have been left inside the equipment.

Failure to follow these instructions will result in death or serious injury.

Procedure Definition

Procedure characteristics	Description
Action	Check the locking and unlocking of the interlocked devices.
Goal	Verify the operation of the interlocking system between interlocked devices.
Frequency	Refer to Recommended Frequency for the Routine End-User Maintenance Program, page 14.
Special indications	–

Procedure characteristics	Description
Necessary tools	–
Related documents, page 6	<ul style="list-style-type: none"> • <i>MasterPacT MTZ1 - VBP Lockable Pushbutton Cover - Instruction Sheet</i> • <i>MasterPacT MTZ1 - Mechanical Interlocking for Source Changeover (2 Sources / Cable) - Instruction Sheet</i> • <i>MasterPacT MTZ1 - Mechanical Interlocking for Source Changeover (2 Sources / Rods) - Instruction Sheet</i> • <i>MasterPacT MTZ2/MTZ3 - VBP Lockable Pushbutton Cover - Instruction Sheet</i> • <i>MasterPacT MTZ2/MTZ3 - Mechanical Interlocking for Source Changeover (2 Sources / Cable) - Instruction Sheet</i> • <i>MasterPacT MTZ2/MTZ3 - Mechanical Interlocking for Source Changeover (2 Sources / Rods) - Instruction Sheet</i> • <i>MasterPacT MTZ2/MTZ3 - Mechanical Interlocking for 3 Sources - Instruction Sheet</i> • <i>MasterPacT MTZ2/MTZ3 - Mechanical Interlocking for 2 Sources and 1 Replacement - Instruction Sheet</i> • <i>MasterPacT MTZ2/MTZ3 - Mechanical Interlocking for 2 Sources and 1 Coupling - Instruction Sheet</i>

Preliminary Conditions

The devices must comply with the conditions specified below. Refer to the MasterPacT *User Guides* to find instructions for operating the devices.

Device installation type	Position of poles	Mechanism	Device position in the chassis
Fixed	Open	Discharged	N/A
Drawout	Open	Discharged	Test

Checking the Locking and Unlocking of Interlocked Devices

Follow the procedure to check the locking and unlocking of the following interlocking systems:

- Cable interlocking system:
 - Two sources
 - Three sources
 - Two sources and one replacement
 - Two sources and one coupling
 - Cable-type door interlock
- Rod interlocking system
- Electrical interlocking system
 - IVE electrical interlocking system
 - Custom electrical interlocking system

Step	Action	Corrective action
1	Perform at least one manual operating sequence without power to check that the interlocking system operates correctly in all situations. Refer to the relevant instruction sheet for the interlocking system installed on the device.	If an interlocking system is not operating correctly, contact your Schneider Electric Services representative.
2	Lock the closing pushbuttons of all interlocked devices with padlocks sharing the same key.	<p>The VBP pushbutton locking accessory is mandatory to provide redundancy in addition to the mechanical interlocking system.</p> <p>Install a VBP pushbutton locking accessory on each interlocked device, if not already installed. Refer to the relevant instruction sheet for accessory installation.</p>

Intermediate End-User Maintenance Procedures

What's in This Part

Mechanism NIII_ZA_1: Check the MCH Gear Motor Charging Time at 0.85 Un.....	79
Mechanism NIII_ZA_2: Check the General Condition of the Mechanism.....	82
Mechanism NIII_ZA_3: Check the Number of Device Operating Cycles.....	88
Breaking Unit NIII_ZA_1: Check the Condition of the Breaking Unit.....	90
Breaking Unit NIII_ZA_2: Check Mounting of Arc Chutes and Filter Cleanliness.....	97
Auxiliaries NIII_ZA_1: Check Operation of Indication Contacts (OF, PF).....	99
Auxiliaries NIII_ZA_2: Check Closing Operation with XF Closing Voltage Release at 0.85 Un.....	103
Auxiliaries NIII_ZA_3: Check Opening Operation with MX Opening Voltage Release at 0.7 Un.....	106
Auxiliaries NIII_ZA_4: Check Closing and Opening Operations with MN Undervoltage Release.....	109
Auxiliaries NIII_ZA_5: Check Time Delay of MNR Delayed Undervoltage Release.....	113
Control Unit NIII_ZA_3: Save Protection Settings, Reports, and Event Logs With EcoStruxure Power Commission Software.....	116
Control Unit NIII_ZA_4: Check Overcurrent Protection.....	120
Chassis NIII_ZA_1: Check Operation of CD, CT, CE Position Contacts and EF Auxiliary Contacts.....	127
Chassis NIII_ZA_2: Check Operation of Safety Shutters.....	135
Chassis NIII_ZA_3: Clean Chassis and Check Presence of Grease on Chassis.....	142
Chassis NIII_ZA_4: Check Disconnecting Contact Clusters.....	146
Power Connections NIII_ZA_1: Check Connection System.....	149

Mechanism NIII_ZA_1: Check the MCH Gear Motor Charging Time at 0.85 Un

Safety Instructions

⚠️⚠️ DANGER

HAZARD OF ELECTRIC SHOCK, EXPLOSION, OR ARC FLASH

- Apply appropriate personal protective equipment (PPE) and follow safe electrical work practices. See NFPA 70E, CSA Z462, NOM 029-STPS, or local equivalent.
- This equipment must only be installed and serviced by qualified electrical personnel.
- Unless specified otherwise in the maintenance procedures, all operations (inspection, test, and preventive maintenance) must be carried out with the device, the chassis, and the auxiliary circuits de-energized.
- Check that the device and the chassis are de-energized on the upstream and downstream terminals.
- Always use a properly rated voltage sensing device to confirm that the device, the chassis, and the auxiliary circuits are de-energized.
- Install safety barriers and display a danger sign.
- During the tests, it is strictly forbidden for anyone to touch the device, the chassis, or the conductors while voltage is applied.
- Before turning on power to this equipment, check that all connections are made with the correct tightening torque and the device is off (open position).
- Before turning on power to this equipment, put all devices, doors, and covers back in place.
- Before turning on power to this equipment, beware of potential hazards and carefully inspect the work area for tools and objects that may have been left inside the equipment.

Failure to follow these instructions will result in death or serious injury.

Procedure Definition

Procedure characteristics	Description
Action	<ul style="list-style-type: none"> • Check the MCH gear motor charging time at 0.85 Un. • Check the continuity of electrical wiring for a drawout device.
Goal	Verify the correct operation of the MCH gear motor.
Frequency	Refer to Recommended Frequency for the Intermediate End-User Maintenance Program, page 15.
Special indications	Connect the MCH gear motor to a power supply.
Necessary tools	<ul style="list-style-type: none"> • Adjustable external power supply • Voltmeter • Stopwatch
Related documents, page 6	<ul style="list-style-type: none"> • <i>MasterPacT MTZ1 IEC Circuit Breakers with MicroLogic Active Control Unit - User Guide</i> • <i>MasterPacT MTZ2/MTZ3 IEC Circuit Breakers with MicroLogic Active Control Unit - User Guide</i> • <i>MasterPacT MTZ1 - MCH Gear Motor - Instruction Sheet</i> • <i>MasterPacT MTZ2/MTZ3 - MCH Gear Motor - Instruction Sheet</i>

Preliminary Conditions

The device must comply with the conditions specified below. Refer to the *MasterPacT MTZ User Guides* to find instructions for operating the device.

Device installation type	Position of poles	Mechanism	Device position in the chassis
Fixed	Open	Discharged	N/A
Drawout	Open	Discharged	Test

MCH Gear Motor Charging Time Definition

The charging time is the time elapsed between the closing order and the moment when the mechanism is fully charged.

The charging time during closing operation and opening/closing operation does not exceed 6 seconds.

Checking the MCH Gear Motor Charging Time During Device Closing



DANGER

HAZARD OF ELECTRIC SHOCK

When using the adjustable external power supply, take all suitable measures to protect against electric shock.

Failure to follow these instructions will result in death or serious injury.

Before starting this check, it is advisable to verify that the device charges electrically with MCH gear motor as per procedure *Mechanism NII_ZA_2*, page 34.

Step	Action	Corrective action
1	Disconnect supply wires B1 and B2 (and B3 if connected) so that the MCH gear motor is not connected to a power supply.	
2	Connect terminals B1 and B2 to the adjustable external power supply.	
3	<p>Set the voltage to 0.85 Un (minimum Un if the setting is for a range of voltages).</p> <p>The MCH gear motor charges the mechanism. The indicators show that the device is open and the mechanism is charged and ready-to-close.</p> <div style="display: flex; align-items: center; gap: 10px;"> <div style="border: 1px solid black; padding: 5px; background-color: #008000; color: white; display: flex; align-items: center; justify-content: center;">  </div> <div style="border: 1px solid black; padding: 5px; background-color: #FFD700; display: flex; align-items: center; justify-content: center;">  </div> </div>	

Step	Action	Corrective action
4	Press the closing pushbutton and start the stopwatch. The device closes and the mechanism is automatically charged.	
5	Stop the stopwatch when the mechanism is charged and not ready-to-close. The charging time should be less than 6 seconds. 	If the charging time exceeds 6 seconds: <ol style="list-style-type: none"> 1. Check that the MCH supply voltage remains at 0.85 Un while the MCH gear motor is charging the mechanism. 2. Do the procedure with another external source connected to terminals B1 and B2. 3. If the time is still too long, replace the MCH gear motor. If the problem persists, contact your Schneider Electric Services representative to replace the breaking unit.

Checking the MCH Gear Motor Charging Time During Device Closing/Opening Sequence

Step	Action	Corrective action
1	Open the device.	
2	Press the closing pushbutton and immediately the opening pushbutton, and then start the stopwatch.	
3	Stop the stopwatch when the indicators show that the device is open and the mechanism is charged and ready-to-close. The charging time should be less than 6 seconds. 	If the charging time exceeds 6 seconds: <ol style="list-style-type: none"> 1. Check that the MCH supply voltage remains at 0.85 Un while the MCH gear motor is charging the mechanism. 2. Do the procedure with another external source connected to terminals B1 and B2. 3. If the time is still too long, replace the MCH gear motor. If the problem persists, contact your Schneider Electric Services representative to replace the breaking unit.

Reconnecting the MCH Gear Motor

Step	Action	Corrective action
1	Reconnect the supply wires (B1, B2, and B3 if present) as they were before executing the procedure.	
2	Open and close the device to check that the MCH gear motor operates properly.	

Mechanism NIII_ZA_2: Check the General Condition of the Mechanism

Safety Instructions

⚡⚠ DANGER

HAZARD OF ELECTRIC SHOCK, EXPLOSION, OR ARC FLASH

- Apply appropriate personal protective equipment (PPE) and follow safe electrical work practices. See NFPA 70E, CSA Z462, NOM 029-STPS, or local equivalent.
- This equipment must only be installed and serviced by qualified electrical personnel.
- Unless specified otherwise in the maintenance procedures, all operations (inspection, test, and preventive maintenance) must be carried out with the device, the chassis, and the auxiliary circuits de-energized.
- Check that the device and the chassis are de-energized on the upstream and downstream terminals.
- Always use a properly rated voltage sensing device to confirm that the device, the chassis, and the auxiliary circuits are de-energized.
- Install safety barriers and display a danger sign.
- During the tests, it is strictly forbidden for anyone to touch the device, the chassis, or the conductors while voltage is applied.
- Before turning on power to this equipment, check that all connections are made with the correct tightening torque and the device is off (open position).
- Before turning on power to this equipment, put all devices, doors, and covers back in place.
- Before turning on power to this equipment, beware of potential hazards and carefully inspect the work area for tools and objects that may have been left inside the equipment.

Failure to follow these instructions will result in death or serious injury.

⚠ DANGER

HAZARD OF DEVICE FALLING

- Be sure that lifting equipment has lifting capacity for the device being lifted.
- Follow manufacturer’s instructions for use of lifting equipment.
- Wear hard hat, safety shoes, and heavy gloves.

Failure to follow these instructions will result in death or serious injury.

Procedure Definition

Procedure characteristics	Description
Action	Check the general condition of the mechanism: <ul style="list-style-type: none"> • Positioning of XF/MX/MN voltage releases on the fixing plate. • Positioning of springs in the groove on the axle. • Condition of springs.
Goal	Verify that the mechanism correctly opens and closes the device.
Frequency	Refer to Recommended Frequency for the Intermediate End-User Maintenance Program, page 15.



Procedure characteristics	Description
Special indications	–
Necessary tools	Torx screwdriver
Related documents, page 6	<ul style="list-style-type: none"> • <i>MasterPacT MTZ1 IEC Circuit Breakers with MicroLogic Active Control Unit - User Guide</i> • <i>MasterPacT MTZ2/MTZ3 IEC Circuit Breakers with MicroLogic Active Control Unit - User Guide</i> • <i>MasterPacT MTZ IEC Circuit Breakers with MicroLogic Active Control Unit - Maintenance Guide</i> • <i>MasterPacT MTZ1/MTZ2/MTZ3 - MN-MX-XF Voltage Releases - Instruction Sheet</i>

Preliminary Conditions

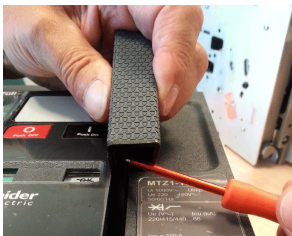

The device must comply with the conditions specified below. Refer to the *MasterPacT MTZ User Guides* to find instructions for operating the device.

Device installation type	Position of poles	Mechanism	Device position in the chassis
Fixed	Open	Discharged	N/A
Drawout	Open	Discharged	Removed from chassis

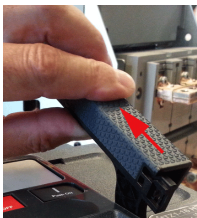
Removing Front Cover

Step	Action	Corrective action
1	<p>For MasterPacT MTZ1: Remove the spring charging handle.</p> <ol style="list-style-type: none"> 1. Insert a thin screwdriver under the bottom left-hand corner of the spring charging handle.  <ol style="list-style-type: none"> 2. Push the screwdriver to unclip the rubber cover of the spring charging handle.  <ol style="list-style-type: none"> 3. Slide the rubber cover to the top and remove it from the spring charging handle. 	
2	Remove the front cover of the device.	

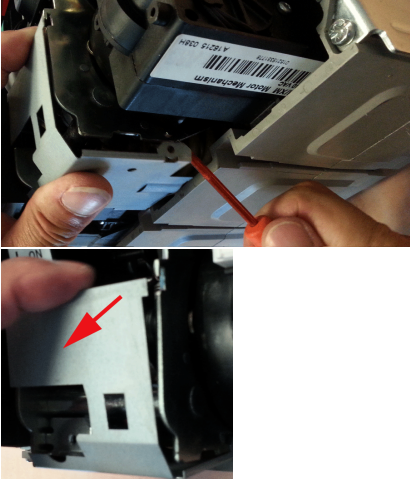
Checking Mechanism

Step	Action	Corrective action
1	<p>Remove the mechanism cover:</p> <ul style="list-style-type: none"> For MasterPacT MTZ1: using a thin screwdriver, release the tab on the left-hand side that holds the mechanism cover in place (do not break or bend the tab) and then free the right-hand side.  <ul style="list-style-type: none"> For MasterPacT MTZ2/MTZ3: unscrew the screw that holds the mechanism cover in place then pull off the front cover. 	<p>If the mechanism cover is damaged, contact your Schneider Electric Services representative.</p>
2	<p>Check the general condition of the mechanism:</p> <ul style="list-style-type: none"> Sufficient grease. No dust. 	<p>If there is dust on the mechanism, or the consistency or color of the grease has changed, contact your Schneider Electric Services representative.</p>

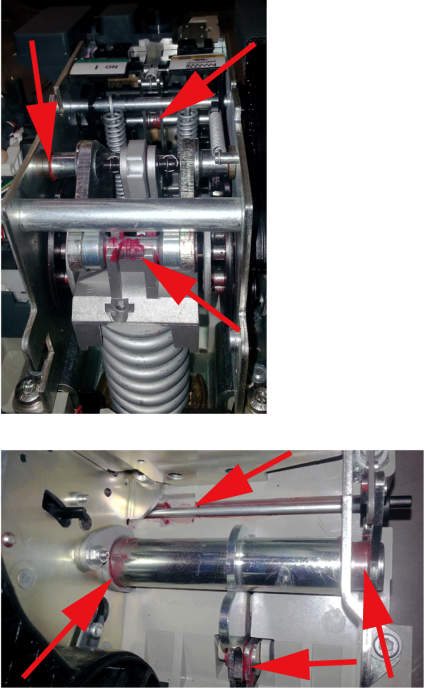
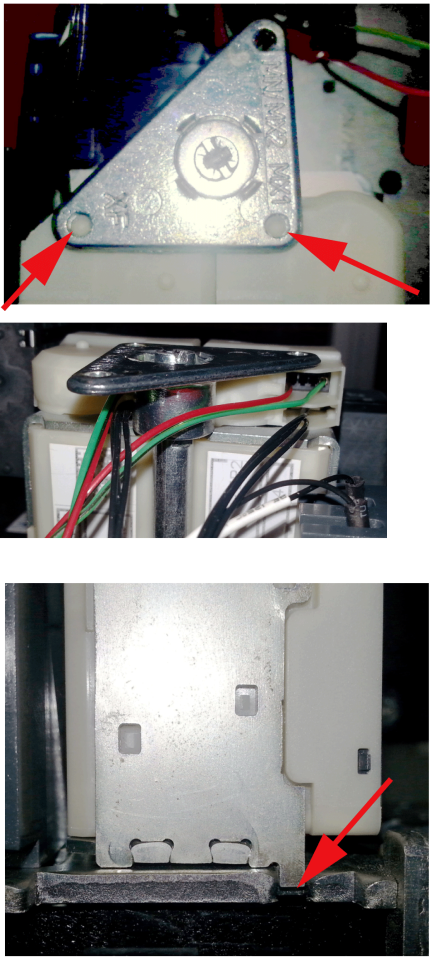
Step	Action	Corrective action
		
3	<p>Check that the XF/MX/MN voltage releases are correctly positioned on the fixing plate.</p> 	<p>If necessary, reposition the voltage releases (refer to <i>MasterPacT MTZ1/MTZ2/MTZ3 - MN-MX-XF Voltage Releases - Instruction Sheet</i>).</p>
4	<p>Check that the springs are present, in good condition, and correctly positioned in the groove on the axle.</p> <ul style="list-style-type: none"> For MasterPacT MTZ1: 	<p>If a spring is damaged or missing, contact your Schneider Electric Services representative.</p>

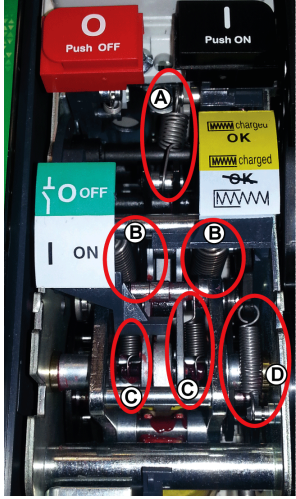
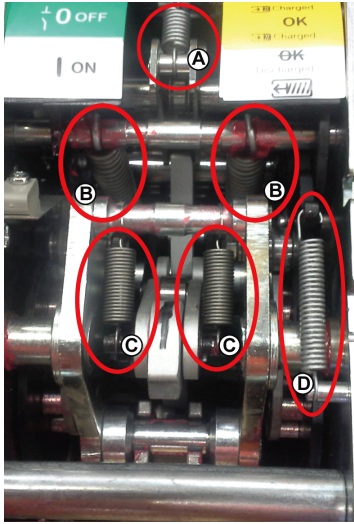
Step	Action	Corrective action
	 <p>A Opening latch</p> <p>B Pole opening springs</p> <p>C Connecting-rod springs</p> <p>D Closing latch</p> <ul style="list-style-type: none"> For MasterPacT MTZ2/MTZ3:  <p>A Opening latch</p> <p>B Pole opening springs</p> <p>C Connecting-rod springs</p> <p>D Closing latch</p>	
5	Manually charge the mechanism.	
6	Check that the springs are correctly positioned.	<p>If a spring is not correctly positioned, carefully put it back into place.</p> <p>If the problem persists, contact your Schneider Electric Services representative.</p>
7	Close the device.	
8	Check that the springs are still correctly positioned.	<p>If a spring is not correctly positioned, carefully put it back into place.</p> <p>If the problem persists, contact your Schneider Electric Services representative.</p>

Step	Action	Corrective action
9	Check the number of operating cycles and compare it with the maximum allowed for the connecting-rod springs as indicated in <i>MasterPacT MTZ IEC Circuit Breakers with MicroLogic Active Control Unit - Maintenance Guide</i> .	If the maximum number has been reached, contact your Schneider Electric Services representative.
10	Put the mechanism cover back in place.	

Reinstalling the Front Cover

⚠ DANGER

HAZARD OF ELECTRIC SHOCK, EXPLOSION OR ARC FLASH

- Put the circuit breaker front cover back in place before energizing the circuit breaker to prevent access to live terminals.
- Do not pinch the wires with the front cover.

Failure to follow these instructions will result in death or serious injury.

Step	Action	Corrective action
1	Put the front cover back in place.	
2	For MasterPacT MTZ1: Put the rubber cover back in place on the spring charging handle.	

Mechanism NIII_ZA_3: Check the Number of Device Operating Cycles

Safety Instructions

⚡⚠ DANGER

HAZARD OF ELECTRIC SHOCK, EXPLOSION, OR ARC FLASH

- Apply appropriate personal protective equipment (PPE) and follow safe electrical work practices. See NFPA 70E, CSA Z462, NOM 029-STPS, or local equivalent.
- This equipment must only be installed and serviced by qualified electrical personnel.
- Unless specified otherwise in the maintenance procedures, all operations (inspection, test, and preventive maintenance) must be carried out with the device, the chassis, and the auxiliary circuits de-energized.
- Check that the device and the chassis are de-energized on the upstream and downstream terminals.
- Always use a properly rated voltage sensing device to confirm that the device, the chassis, and the auxiliary circuits are de-energized.
- Install safety barriers and display a danger sign.
- During the tests, it is strictly forbidden for anyone to touch the device, the chassis, or the conductors while voltage is applied.
- Before turning on power to this equipment, check that all connections are made with the correct tightening torque and the device is off (open position).
- Before turning on power to this equipment, put all devices, doors, and covers back in place.
- Before turning on power to this equipment, beware of potential hazards and carefully inspect the work area for tools and objects that may have been left inside the equipment.

Failure to follow these instructions will result in death or serious injury.

Procedure Definition

Procedure characteristics	Description
Action	Check the number of device operating cycles on the CDM operation counter, if present.
Goal	Verify that the maximum recommended number of operating cycles has not been exceeded.
Frequency	Refer to Recommended Frequency for the Intermediate End-User Maintenance Program, page 14.
Special indications	–
Necessary tools	–
Related documents, page 6	<ul style="list-style-type: none"> • <i>MasterPacT MTZ1 IEC Circuit Breakers with MicroLogic Active Control Unit - User Guide</i> • <i>MasterPacT MTZ2/MTZ3 IEC Circuit Breakers with MicroLogic Active Control Unit - User Guide</i> • <i>MasterPacT MTZ - MicroLogic Active Control Unit - User Guide</i> • <i>MasterPacT MTZ1 - CDM Operation Counter - Instruction Sheet</i> • <i>MasterPacT MTZ2/MTZ3 - CDM Operation Counter - Instruction Sheet</i> • <i>MasterPacT MTZ IEC Circuit Breakers with MicroLogic Active Control Unit - Maintenance Guide</i> for operating limits

Preliminary Conditions

The device must comply with the conditions specified below. Refer to the *MasterPacT MTZ User Guides* to find instructions for operating the device.

Device installation type	Position of poles	Mechanism	Device position in the chassis
Fixed	Open	Discharged	N/A
Drawout	Open	Discharged	Test

Checking Operating Cycle with the Optional CDM Operation Counter

The CDM operation counter increments each time the device performs an open/close cycle.

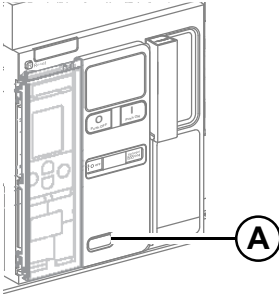
Step	Action	Corrective action
1	<p>Read the value on the CDM operation counter (A).</p> 	
2	<p>Compare the value with the maximum number of mechanical operations indicated in <i>MasterPacT MTZ IEC Circuit Breakers with MicroLogic Active Control Unit - Maintenance Guide</i>.</p>	<ul style="list-style-type: none"> • If the limit has been reached, contact your Schneider Electric Services representative to replace the breaking unit. • If the limit is close, contact your Schneider Electric Services representative to schedule the breaking unit replacement.

Breaking Unit NIII_ZA_1: Check the Condition of the Breaking Unit

Safety Instructions

⚡⚠ DANGER

HAZARD OF ELECTRIC SHOCK, EXPLOSION, OR ARC FLASH

- Apply appropriate personal protective equipment (PPE) and follow safe electrical work practices. See NFPA 70E, CSA Z462, NOM 029-STPS, or local equivalent.
- This equipment must only be installed and serviced by qualified electrical personnel.
- Unless specified otherwise in the maintenance procedures, all operations (inspection, test, and preventive maintenance) must be carried out with the device, the chassis, and the auxiliary circuits de-energized.
- Check that the device and the chassis are de-energized on the upstream and downstream terminals.
- Always use a properly rated voltage sensing device to confirm that the device, the chassis, and the auxiliary circuits are de-energized.
- Install safety barriers and display a danger sign.
- During the tests, it is strictly forbidden for anyone to touch the device, the chassis, or the conductors while voltage is applied.
- Before turning on power to this equipment, check that all connections are made with the correct tightening torque and the device is off (open position).
- Before turning on power to this equipment, put all devices, doors, and covers back in place.
- Before turning on power to this equipment, beware of potential hazards and carefully inspect the work area for tools and objects that may have been left inside the equipment.

Failure to follow these instructions will result in death or serious injury.

⚠ DANGER

HAZARD OF DEVICE FALLING

- Be sure that lifting equipment has lifting capacity for the device being lifted.
- Follow manufacturer’s instructions for use of lifting equipment.
- Wear hard hat, safety shoes, and heavy gloves.

Failure to follow these instructions will result in death or serious injury.

Procedure Definition

Procedure characteristics	Description
Action	Check the condition of the elements of the breaking unit: <ul style="list-style-type: none"> • Separator plates and sides of arc chute assembly. • Fixed and moving contact tips. • Arcing contacts which protect the contact tips.
Goal	Verify that all subassemblies participating in arc extinction for rated and short-circuit currents correctly operate.
Frequency	Refer to Recommended Frequency for the Intermediate End-User Maintenance Program, page 15.

Procedure characteristics	Description
Special indications	-
Necessary tools	Torque wrench
Related documents, page 6	<ul style="list-style-type: none"> • <i>MasterPacT MTZ1 IEC Circuit Breakers with MicroLogic Active Control Unit - User Guide</i> • <i>MasterPacT MTZ2/MTZ3 IEC Circuit Breakers with MicroLogic Active Control Unit - User Guide</i> • <i>MasterPacT MTZ IEC Circuit Breakers with MicroLogic Active Control Unit - Maintenance Guide</i> • <i>MasterPacT MTZ1 - Arc Chute - Instruction Sheet</i> • <i>MasterPacT MTZ2/MTZ3 - Arc Chute - Instruction Sheet</i>

Preliminary Conditions

The device must comply with the conditions specified below. Refer to the *MasterPacT MTZ User Guides* to find instructions for operating the device.

Device installation type	Position of poles	Mechanism	Device position in the chassis
Fixed	Open	Discharged	N/A
Drawout	Open	Discharged	Removed from chassis

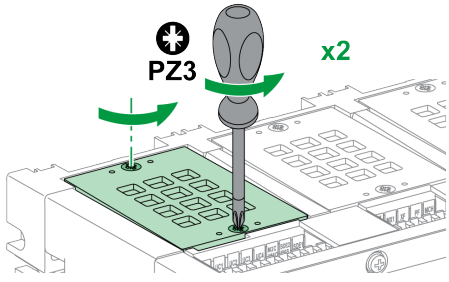
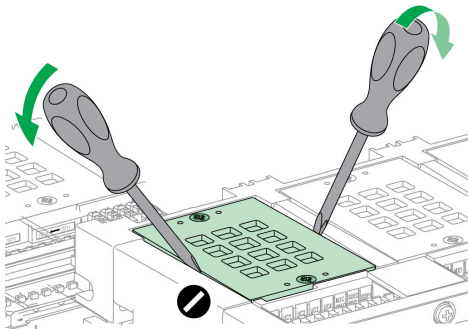

Checking Separator Plates

Execute the following procedure for each arc chute and one arc chute at a time.

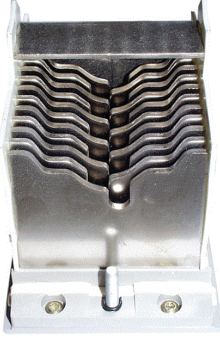
Step	Action	Corrective action
1	<p>Remove the fixing screws on one arc chute.</p>  <p>NOTE: Do not remove the other arc chutes.</p>	
2	<p>Remove the arc chute.</p>  <p>NOTE: Do not turn the arc chute upside down when removing it so that the fixing screws do not fall in the arc chamber.</p>	

Step	Action	Corrective action
3	<p>Check the separator plates: the separator plates must not be corroded, they may be blackened but must not be significantly damaged.</p> <p>Example: MasterPacT MTZ2 16 H1 with separator plates OK after 7,500 cycles at In.</p> 	<p>If damage is extensive, replace the arc chute (refer to <i>MasterPacT MTZ - Arc Chute - Instruction Sheet</i>).</p> <p>Example: MasterPacT MTZ2 16 H1 with new separator plates.</p> 
4	<p>Compare the number of electrical operating cycles with the maximum values indicated in <i>MasterPacT MTZ IEC Circuit Breakers with MicroLogic Active Control Unit - Maintenance Guide</i>.</p>	<p>Depending on the number of electrical operating cycles and state of separator plates, replace the arc chute (refer to <i>MasterPacT MTZ - Arc Chute - Instruction Sheet</i>).</p> <p>Refer to the <i>MasterPacT MTZ Catalog</i> for spare parts.</p>

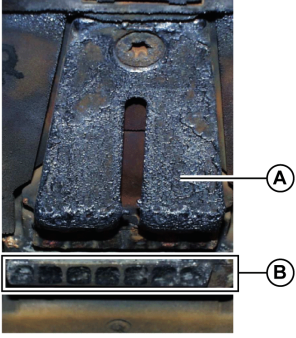
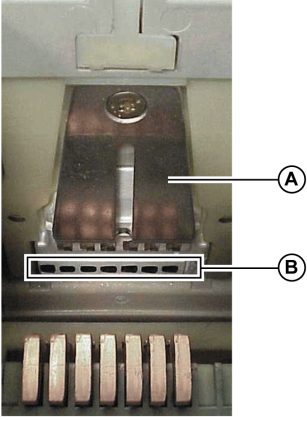
Checking Surface of Arcing Contact and Fixed and Moving Contact Tips

Step	Action	Corrective action
1	<p>With the arc chute removed, check the surface of the arcing contact and fixed contact tips. Example: MasterPacT MTZ2 16 H1 with arcing contact and fixed contact tips OK after 7,500 operating cycles at In.</p>  <p>A Arcing contact B Fixed contact tips</p>	<p>If the arcing contact or fixed contact tips are extensively damaged, contact your Schneider Electric Services representative to replace the breaking unit. Example: MasterPacT MTZ2 16 H1 with new contact tips and arcing contact.</p>  <p>A Arcing contact B Fixed contact tips</p>
2	<p>Check the surface of the moving contact tips. Example: MasterPacT MTZ1 with moving contact tips OK after 7,500 operating cycles at In.</p> 	<p>If the moving contact tips are extensively damaged, contact your Schneider Electric Services representative to replace the breaking unit. Example: MasterPacT MTZ1 16 H1 with new contact tips.</p> 
3	<p>Compare the number of operating cycles at In with the maximum values indicated in <i>MasterPacT MTZ IEC Circuit Breakers with MicroLogic Active Control Unit - Maintenance Guide</i>.</p>	<p>If the limit has been reached, contact your Schneider Electric Services representative to replace the breaking unit. Example: For MasterPacT MTZ2 16 H1, the breaking unit must be changed when 1,000 cycles are reached.</p>

Checking Contact-Wear Indicator On MasterPacT MTZ1

⚡⚠ DANGER

HAZARD OF ELECTRIC SHOCK, EXPLOSION, OR ARC FLASH

- The fixed device must be de-energized on the upstream and downstream terminals.
- Always use a properly rated voltage sensing device to confirm that the device and the auxiliary circuits are de-energized.

Failure to follow these instructions will result in death or serious injury.

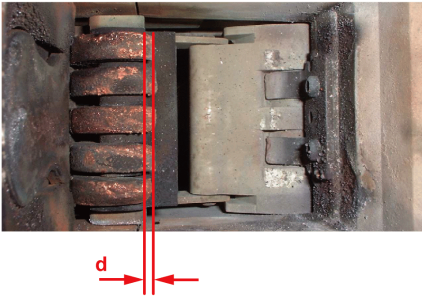
Step	Action	Corrective action
1	Close the device	
2	<p>Check that the distance between the edge of the plastic and the arcing horn is at least 1 mm as shown below:</p>  <ul style="list-style-type: none"> • If $1\text{ mm} \leq d < 3\text{ mm}$, contact tips are OK. • If $d < 1\text{ mm}$, contact tips are worn. 	<p>If $d < 1\text{ mm}$, the contact tips are worn.</p> <p>Contact your Schneider Electric Services representative to replace the breaking unit.</p>





Checking Contact-Wear Indicator On MasterPacT MTZ2/ MTZ3

⚡⚠ DANGER

HAZARD OF ELECTRIC SHOCK, EXPLOSION, OR ARC FLASH

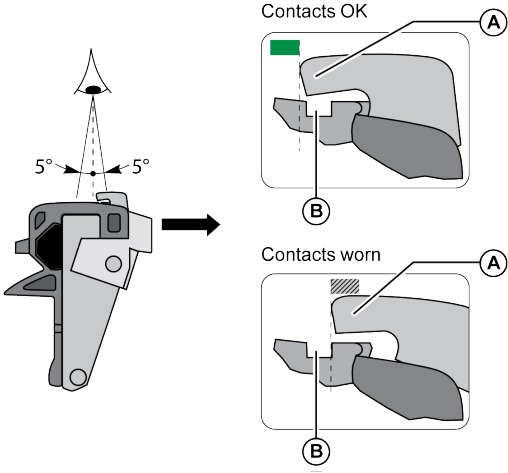
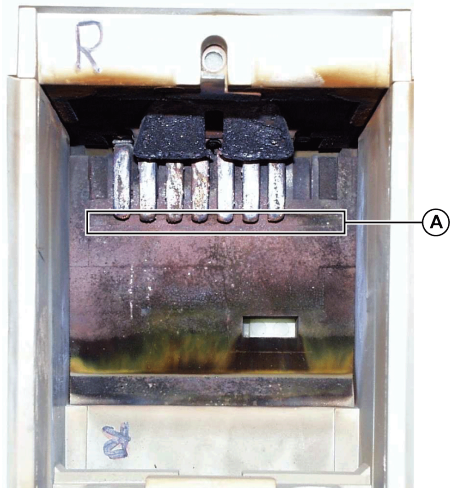
- The fixed device must be de-energized on the upstream and downstream terminals.
- Always use a properly rated voltage sensing device to confirm that the device and the auxiliary circuits are de-energized.

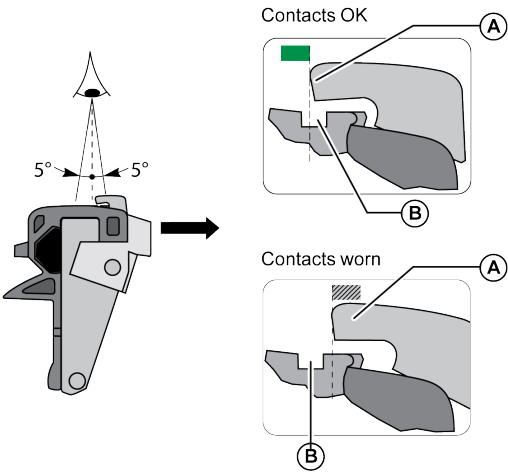
Failure to follow these instructions will result in death or serious injury.

Step	Action	Corrective action
1	Close the device.	
2	<p>Check that the channel is covered by the arcing horn for Type A devices:</p> <ul style="list-style-type: none"> • MTZ2 08–40 H1, H2 • MTZ2 08–20 N1  <p>A Arcing horn B Channel</p> <p>Example: Contact-wear indicator on a MasterPacT MTZ2 device OK after 7,500 operating cycles at In.</p> 	<p>If the channel is no longer covered, the contact tips are worn.</p> <p>Contact your Schneider Electric Services representative to replace the breaking unit.</p> <p>Example: Original state of contact-wear indicator on a MasterPacT MTZ2 device.</p>  <p>A Channel</p>
3	<p>Check that the channel is covered by the arcing horn for Type B devices:</p> <ul style="list-style-type: none"> • MTZ2 08-20 L1 • MTZ3 40-63 H1, H2  <p>A Arcing horn B Channel</p>	<p>If the channel is no longer covered, the contact tips are worn.</p> <p>Contact your Schneider Electric Services representative to replace the breaking unit.</p> <p>Example: Original state of contact-wear indicator on a MasterPacT MTZ2 device.</p>  <p>A Channel</p>

Step	Action	Corrective action
	A Arcing horn B Channel	

Checking Sides of Arc Chamber

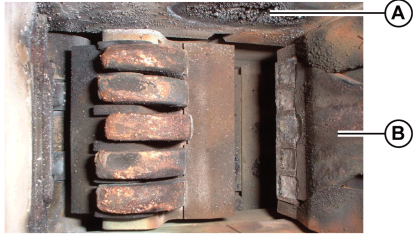
Step	Action	Corrective action
1	Check the sides of the arc chamber. The sides of the arc chamber must not be cracked, they may be blackened but must show no traces of burns or holes.  A Traces of burns B Blackened parts	If the sides are burned or punctured, contact your Schneider Electric Services representative to replace the breaking unit.
2	Put the arc chute back in place. NOTE: For MasterPacT MTZ1: Make sure that the arrow on the top of the arc chute points towards the mechanism.	
3	Tighten the arc chute fixing screws to the recommended value using a torque wrench: <ul style="list-style-type: none"> • For MasterPacT MTZ1: 1.5 N•m • For MasterPacT MTZ2/MTZ3: 7 N•m 	If a screw cannot be tightened at the recommended value, contact your Schneider Electric Services representative.
4	Do the procedure from the beginning for another arc chute on the device.	

Breaking Unit NIII_ZA_2: Check Mounting of Arc Chutes and Filter Cleanliness

Safety Instructions

⚠️⚠️ DANGER

HAZARD OF ELECTRIC SHOCK, EXPLOSION, OR ARC FLASH

- Apply appropriate personal protective equipment (PPE) and follow safe electrical work practices. See NFPA 70E, CSA Z462, NOM 029-STPS, or local equivalent.
- This equipment must only be installed and serviced by qualified electrical personnel.
- Unless specified otherwise in the maintenance procedures, all operations (inspection, test, and preventive maintenance) must be carried out with the device, the chassis, and the auxiliary circuits de-energized.
- Check that the device and the chassis are de-energized on the upstream and downstream terminals.
- Always use a properly rated voltage sensing device to confirm that the device, the chassis, and the auxiliary circuits are de-energized.
- Install safety barriers and display a danger sign.
- During the tests, it is strictly forbidden for anyone to touch the device, the chassis, or the conductors while voltage is applied.
- Before turning on power to this equipment, check that all connections are made with the correct tightening torque and the device is off (open position).
- Before turning on power to this equipment, put all devices, doors, and covers back in place.
- Before turning on power to this equipment, beware of potential hazards and carefully inspect the work area for tools and objects that may have been left inside the equipment.

Failure to follow these instructions will result in death or serious injury.

⚠️ DANGER

HAZARD OF DEVICE FALLING

- Be sure that lifting equipment has lifting capacity for the device being lifted.
- Follow manufacturer’s instructions for use of lifting equipment.
- Wear hard hat, safety shoes, and heavy gloves.

Failure to follow these instructions will result in death or serious injury.

Procedure Definition

Procedure characteristics	Description
Action	<ul style="list-style-type: none"> • Check that the arc chutes are properly tightened. • Check that the filters are clean.
Goal	Verify the breaking performance of the device during a short-circuit.
Frequency	Refer to Recommended Frequency for the Intermediate End-User Maintenance Program, page 14.
Special indications	-

Procedure characteristics	Description
Necessary tools	<ul style="list-style-type: none"> • Torque wrench • Vacuum cleaner
Related documents, page 6	<ul style="list-style-type: none"> • <i>MasterPacT MTZ1 IEC Circuit Breakers with MicroLogic Active Control Unit - User Guide</i> • <i>MasterPacT MTZ2/MTZ3 IEC Circuit Breakers with MicroLogic Active Control Unit - User Guide</i> • <i>MasterPacT MTZ1 - Arc Chute - Instruction Sheet</i> • <i>MasterPacT MTZ2/MTZ3 - Arc Chute - Instruction Sheet</i>

Preliminary Conditions

The device must comply with the conditions specified below. Refer to the *MasterPacT MTZ User Guides* to find instructions for operating the device.

Device installation type	Position of poles	Mechanism	Device position in the chassis
Fixed	Open	Discharged	N/A
Drawout	Open	Discharged	Disconnected and Removed from chassis

Checking Mounting of Arc Chutes and Filter Cleanliness

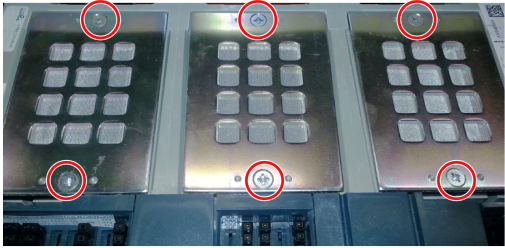
Step	Action	Corrective action
1	<p>Check the presence of all screws on the arc chutes.</p>  <p>NOTE: The presence of all screws is mandatory to help to prevent the ionized gas from leaking through the edges of the arc chute.</p>	<p>If screws are damaged or missing, contact your Schneider Electric Services representative.</p>
2	<p>Unscrew the screws on the arc chutes, then tighten them to the recommended value using a torque wrench:</p> <ul style="list-style-type: none"> • For MasterPacT MTZ1: 1.5 N•m • For MasterPacT MTZ2/MTZ3: 7 N•m 	<p>If a screw cannot be tightened at the recommended value, contact your Schneider Electric Services representative.</p>
3	<p>Use a vacuum cleaner to remove the dust deposited on the filters.</p> <p>NOTE: To avoid soiling the filters:</p> <ul style="list-style-type: none"> • Do not blow air on the filter. • Do not use a cloth, particularly if there is dust and grease. 	<p>If the filters are still dirty (for example, greasy compound), replace the arc chutes (refer to <i>MasterPacT MTZ - Arc Chute - Instruction Sheet</i>).</p> <p>Refer to the <i>MasterPacT MTZ Catalog</i> for spare parts.</p>

Auxiliaries NIII_ZA_1: Check Operation of Indication Contacts (OF, PF)

Safety Instructions

⚠️⚠️ DANGER

HAZARD OF ELECTRIC SHOCK, EXPLOSION, OR ARC FLASH

- Apply appropriate personal protective equipment (PPE) and follow safe electrical work practices. See NFPA 70E, CSA Z462, NOM 029-STPS, or local equivalent.
- This equipment must only be installed and serviced by qualified electrical personnel.
- Unless specified otherwise in the maintenance procedures, all operations (inspection, test, and preventive maintenance) must be carried out with the device, the chassis, and the auxiliary circuits de-energized.
- Check that the device and the chassis are de-energized on the upstream and downstream terminals.
- Always use a properly rated voltage sensing device to confirm that the device, the chassis, and the auxiliary circuits are de-energized.
- Install safety barriers and display a danger sign.
- During the tests, it is strictly forbidden for anyone to touch the device, the chassis, or the conductors while voltage is applied.
- Before turning on power to this equipment, check that all connections are made with the correct tightening torque and the device is off (open position).
- Before turning on power to this equipment, put all devices, doors, and covers back in place.
- Before turning on power to this equipment, beware of potential hazards and carefully inspect the work area for tools and objects that may have been left inside the equipment.

Failure to follow these instructions will result in death or serious injury.

Procedure Definition

Procedure characteristics	Description
Action	Check the operation of indication contacts OF and PF.
Goal	Verify electrical continuity of the installed contacts and contact robustness.
Frequency	Refer to Recommended Frequency for the Intermediate End-User Maintenance Program, page 15.
Special indications	–
Necessary tools	<ul style="list-style-type: none"> • Ohmmeter • LV847074SP terminal block
Related documents, page 6	<ul style="list-style-type: none"> • <i>MasterPacT MTZ1 IEC Circuit Breakers with MicroLogic Active Control Unit - User Guide</i> • <i>MasterPacT MTZ2/MTZ3 IEC Circuit Breakers with MicroLogic Active Control Unit - User Guide</i> • <i>MasterPacT MTZ1 - OF ON/OFF Indication Contacts - Instruction Sheet</i> • <i>MasterPacT MTZ2/MTZ3 - OF ON/OFF Indication Contacts - Instruction Sheet</i> • <i>MasterPacT MTZ1/MTZ2/MTZ3 - PF Ready-To-Close Contact - Instruction Sheet</i> • <i>MasterPacT MTZ1/MTZ2/MTZ3 - Auxiliary Terminals - Instruction Sheet</i>

Preliminary Conditions

The device must comply with the conditions specified below. Refer to the *MasterPacT MTZ User Guides* to find instructions for operating the device.

Device installation type	Position of poles	Mechanism	Device position in the chassis
Fixed	Open	Discharged	N/A
Drawout	Open	Discharged	Test

OF Indication Contact Wiring Diagram

The number of OF indication contacts depends on the device type:

- A block of four OF indication contacts is supplied as standard on MasterPacT MTZ1 and MasterPacT MTZ2/MTZ3 devices.

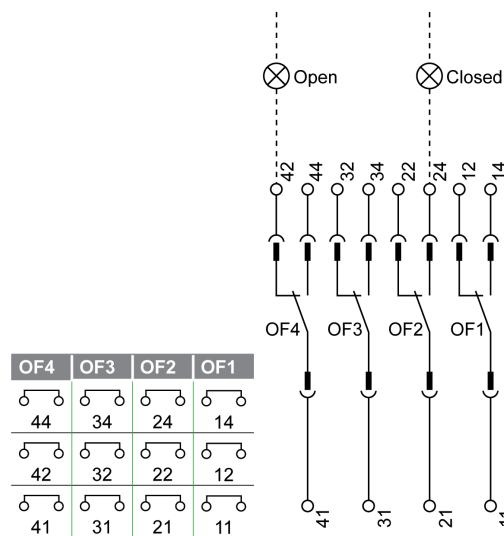

- Two additional blocks of four OF indication contacts (OF11–OF14, OF21–OF24) are optional on MasterPacT MTZ2/MTZ3 devices.

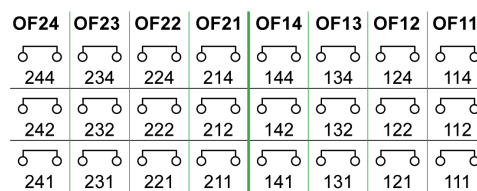

Checking Operation of OF Indication Contacts

Do this procedure for each OF indication contact of the device.

Step	Action	Corrective action
1	Check that the device is in the open position.	
2	Check electrical continuity between terminals: <ul style="list-style-type: none"> 41-42 31-32 21-22 11-12 If additional OF blocks are installed, check all terminals.	In case of electrical non-continuity between terminals: <ul style="list-style-type: none"> For a fixed device: replace the OF contact (refer to <i>MasterPacT MTZ - OF ON/OFF Indication Contacts - Instruction Sheet</i>) and do the procedure again.

Step	Action	Corrective action
		<ul style="list-style-type: none"> • For a drawout device, check that the OF contact operates correctly, as follows: <ol style="list-style-type: none"> 1. Put the device in the withdrawn position. 2. Insert an LV847074SP terminal block at the appropriate location on the device.  <ol style="list-style-type: none"> 3. Check the electrical continuity directly on the LV847074SP terminal block: <ul style="list-style-type: none"> ◦ If the OF contact operates correctly, replace the auxiliary terminal block (refer to <i>MasterPacT MTZ1/MTZ2/MTZ3 - Auxiliary Terminals - Instruction Sheet</i>) and do the procedure again with the device in the test position. ◦ If the OF contact does not operate correctly, replace the OF contact and do the procedure again with the device in the test position. <p>Refer to the <i>MasterPacT MTZ Catalog</i> for spare parts.</p> <p>If the problem persists, contact your Schneider Electric Services representative.</p>
3	Close the device.	
4	Check electrical continuity between terminals: <ul style="list-style-type: none"> • 41-44 • 31-34 • 21-24 • 11-14 If additional OF blocks are installed, check all terminals.	In case of electrical non-continuity between terminals, see the corrective action concerning electrical continuity above.

PF Ready-To-Close Contact Wiring Diagram

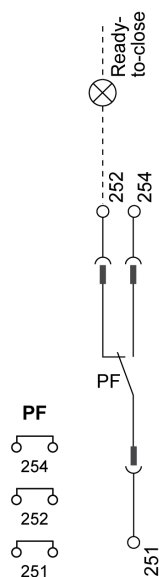

Checking Operation of PF Ready-To-Close Contact

Step	Action	Corrective action
1	Close the device.	
2	<p>Verify that the PF contact indicates that the device is not ready-to-close:</p> <ul style="list-style-type: none"> • Check electrical continuity between terminals 251-254. • Check electrical non-continuity between terminals 251-252. 	<p>In case of electrical non-continuity between terminals 251-254, or electrical continuity between terminals 251-252:</p> <ul style="list-style-type: none"> • For a fixed device: replace the PF contact (refer to <i>MasterPacT MTZ1/MTZ2/MTZ3 - PF Ready-To-Close Contact - Instruction Sheet</i>) and do the procedure again. • For a drawout device, check that the PF contact operates correctly, as follows: <ol style="list-style-type: none"> 1. Put the device in the withdrawn position. 2. Insert an LV847074SP terminal block at the appropriate location on the device. <div style="text-align: center;">  </div> <ul style="list-style-type: none"> 3. Check the electrical continuity and non-continuity directly on the LV847074SP terminal block: <ul style="list-style-type: none"> ◦ If the PF contact operates correctly, replace the auxiliary terminal block (refer to <i>MasterPacT MTZ1/MTZ2/MTZ3 - Auxiliary Terminals - Instruction Sheet</i>) and do the procedure again with the device in the test position. ◦ If the PF contact does not operate correctly, replace the PF contact and do the procedure again with the device in the test position. <p>Refer to the <i>MasterPacT MTZ Catalog</i> for spare parts.</p> <p>If the problem persists, contact your Schneider Electric Services representative.</p>
3	Open the device.	
4	Charge the mechanism.	
5	<ul style="list-style-type: none"> • Check that the device is not tripped. • Check that the device does not have a permanent opening order from an MN undervoltage release. • Check that the device does not have a permanent opening order from an MX opening voltage release. <p>The device is ready-to-close.</p>	<ul style="list-style-type: none"> • If the device is tripped, reset it by pushing in the blue fault-trip reset button. • If the device is equipped with an MN undervoltage release, either connect it to the power supply with its rated voltage or remove the MN undervoltage release. • If the device is equipped with an MX opening voltage release, remove the power supply to the MX.
6	<p>Verify that the PF contact indicates that the device is ready-to-close:</p> <ul style="list-style-type: none"> • Check electrical continuity between terminals 251-252. • Check electrical non-continuity between terminals 251-254. 	<p>In case of electrical non-continuity between terminals 251-252, or electrical continuity between terminals 251-254, see the corrective action concerning electrical continuity above.</p>

Auxiliaries NIII_ZA_2: Check Closing Operation with XF Closing Voltage Release at 0.85 Un

Safety Instructions

⚠️⚠️ DANGER

HAZARD OF ELECTRIC SHOCK, EXPLOSION, OR ARC FLASH

- Apply appropriate personal protective equipment (PPE) and follow safe electrical work practices. See NFPA 70E, CSA Z462, NOM 029-STPS, or local equivalent.
- This equipment must only be installed and serviced by qualified electrical personnel.
- Unless specified otherwise in the maintenance procedures, all operations (inspection, test, and preventive maintenance) must be carried out with the device, the chassis, and the auxiliary circuits de-energized.
- Check that the device and the chassis are de-energized on the upstream and downstream terminals.
- Always use a properly rated voltage sensing device to confirm that the device, the chassis, and the auxiliary circuits are de-energized.
- Install safety barriers and display a danger sign.
- During the tests, it is strictly forbidden for anyone to touch the device, the chassis, or the conductors while voltage is applied.
- Before turning on power to this equipment, check that all connections are made with the correct tightening torque and the device is off (open position).
- Before turning on power to this equipment, put all devices, doors, and covers back in place.
- Before turning on power to this equipment, beware of potential hazards and carefully inspect the work area for tools and objects that may have been left inside the equipment.

Failure to follow these instructions will result in death or serious injury.

⚠️ DANGER

HAZARD OF DEVICE FALLING

- Be sure that lifting equipment has lifting capacity for the device being lifted.
- Follow manufacturer’s instructions for use of lifting equipment.
- Wear hard hat, safety shoes, and heavy gloves.

Failure to follow these instructions will result in death or serious injury.

Procedure Definition

Procedure characteristics	Description
Action	Check closing the device with the XF closing voltage release at 0.85 Un.
Goal	Verify that the device closes electrically at Umin.
Frequency	Refer to Recommended Frequency for the Intermediate End-User Maintenance Program, page 15.
Special indications	Connect the XF closing voltage release to an external power supply.

Procedure characteristics	Description
Necessary tools	<ul style="list-style-type: none"> Adjustable external power supply Voltmeter External pushbutton
Related documents, page 6	<ul style="list-style-type: none"> MasterPacT MTZ1 IEC Circuit Breakers with MicroLogic Active Control Unit - User Guide MasterPacT MTZ2/MTZ3 IEC Circuit Breakers with MicroLogic Active Control Unit - User Guide MasterPacT MTZ1/MTZ2/MTZ3 - MN-MX-XF Voltage Releases - Instruction Sheet

Preliminary Conditions

The device must comply with the conditions specified below. Refer to the *MasterPacT MTZ User Guides* to find instructions for operating the device.

Device installation type	Position of poles	Mechanism	Device position in the chassis
Fixed	Open	Charged	N/A
Drawout	Open	Charged	Removed from chassis

XF Closing Voltage Release Wiring Diagram

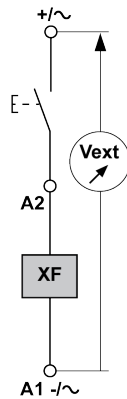
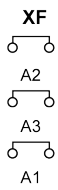

Closing Procedure with the XF Closing Voltage Release

⚠ ⚠ DANGER

HAZARD OF ELECTRIC SHOCK

When using the adjustable external power supply, take all suitable measures to protect against electric shock.

Failure to follow these instructions will result in death or serious injury.

Before starting this check, it is advisable to execute a few electrical opening and closing cycles as per procedure Mechanism NII_ZA_1, page 28.

Step	Action	Corrective action
1	Disconnect supply wires on the customer terminal block.	
2	Connect the adjustable external power supply and external pushbutton according to the corresponding wiring diagram above.	
3	Set the external power supply voltage to 0.85 Un (Un = customer auxiliary voltage).	
4	Press the external pushbutton to close the device. The device closes.	If the device does not close: <ol style="list-style-type: none"> 1. Check that the power supply voltage is not lower than 0.85 Un and do the procedure again. 2. If the device still does not close, replace the XF closing voltage release (refer to <i>MasterPacT MTZ1/MTZ2/MTZ3 - MN-MX-XF Voltage Releases - Instruction Sheet</i>). If the problem persists, contact your Schneider Electric Services representative.
5	Reconnect the customer terminal block according to the initial wiring.	
6	Check that the device electrically closes according to procedure Mechanism NII_ZA_1, page 28.	

Auxiliaries NIII_ZA_3: Check Opening Operation with MX Opening Voltage Release at 0.7 Un

Safety Instructions

⚡ ⚠ DANGER

HAZARD OF ELECTRIC SHOCK, EXPLOSION, OR ARC FLASH

- Apply appropriate personal protective equipment (PPE) and follow safe electrical work practices. See NFPA 70E, CSA Z462, NOM 029-STPS, or local equivalent.
- This equipment must only be installed and serviced by qualified electrical personnel.
- Unless specified otherwise in the maintenance procedures, all operations (inspection, test, and preventive maintenance) must be carried out with the device, the chassis, and the auxiliary circuits de-energized.
- Check that the device and the chassis are de-energized on the upstream and downstream terminals.
- Always use a properly rated voltage sensing device to confirm that the device, the chassis, and the auxiliary circuits are de-energized.
- Install safety barriers and display a danger sign.
- During the tests, it is strictly forbidden for anyone to touch the device, the chassis, or the conductors while voltage is applied.
- Before turning on power to this equipment, check that all connections are made with the correct tightening torque and the device is off (open position).
- Before turning on power to this equipment, put all devices, doors, and covers back in place.
- Before turning on power to this equipment, beware of potential hazards and carefully inspect the work area for tools and objects that may have been left inside the equipment.

Failure to follow these instructions will result in death or serious injury.

Procedure Definition

Procedure characteristics	Description
Action	Check opening the device with the MX opening voltage release at 0.7 Un.
Goal	Verify that the device opens electrically at Umin.
Frequency	Refer to Recommended Frequency for the Intermediate End-User Maintenance Program, page 15.
Special indications	Connect the MX opening voltage release to an external power supply.
Necessary tools	<ul style="list-style-type: none"> • Adjustable external power supply • Voltmeter • External pushbutton
Related documents, page 6	<ul style="list-style-type: none"> • <i>MasterPacT MTZ1 IEC Circuit Breakers with MicroLogic Active Control Unit - User Guide</i> • <i>MasterPacT MTZ2/MTZ3 IEC Circuit Breakers with MicroLogic Active Control Unit - User Guide</i> • <i>MasterPacT MTZ1/MTZ2/MTZ3 - MN-MX-XF Voltage Releases - Instruction Sheet</i>

Preliminary Conditions

The device must comply with the conditions specified below. Refer to the *MasterPacT MTZ User Guides* to find instructions for operating the device.

Device installation type	Position of poles	Mechanism	Device position in the chassis
Fixed	Closed	Charged or discharged	N/A
Drawout	Closed	Charged or discharged	Test

MX Opening Voltage Release Wiring Diagram

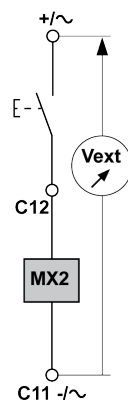
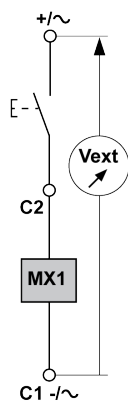
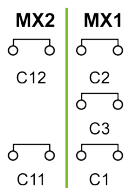

Opening Procedure with the MX Opening Voltage Release

⚠️ DANGER

HAZARD OF ELECTRIC SHOCK

When using the adjustable external power supply, take all suitable measures to protect against electric shock.

Failure to follow these instructions will result in death or serious injury.

Before starting this check, it is advisable to execute a few electrical opening and closing cycles as per procedure Mechanism NII_ZA_1, page 28.

Step	Action	Corrective action
1	Disconnect supply wires on the customer terminal block.	
2	Connect the adjustable external power supply and external pushbutton according to the corresponding wiring diagram above.	
3	Set the external power supply voltage to 0.7 Un (Un = customer auxiliary voltage).	
4	Press the external pushbutton to open the device. The device opens.	If the device does not open: 1. Check that the power supply voltage is not below 0.7 Un and do the procedure again. 2. If the device still does not open, replace the MX opening voltage release (refer to <i>MasterPacT MTZ1/MTZ2/MTZ3 - MN-MX-XF Voltage Releases - Instruction Sheet</i>).

Step	Action	Corrective action
		If the problem persists, contact your Schneider Electric Services representative.
5	Reconnect the customer terminal block according to the initial wiring.	
6	Check that the device electrically opens according to procedure Mechanism NII_ZA_1, page 28.	

Auxiliaries NIII_ZA_4: Check Closing and Opening Operations with MN Undervoltage Release

Safety Instructions

⚠️⚠️ DANGER

HAZARD OF ELECTRIC SHOCK, EXPLOSION, OR ARC FLASH

- Apply appropriate personal protective equipment (PPE) and follow safe electrical work practices. See NFPA 70E, CSA Z462, NOM 029-STPS, or local equivalent.
- This equipment must only be installed and serviced by qualified electrical personnel.
- Unless specified otherwise in the maintenance procedures, all operations (inspection, test, and preventive maintenance) must be carried out with the device, the chassis, and the auxiliary circuits de-energized.
- Check that the device and the chassis are de-energized on the upstream and downstream terminals.
- Always use a properly rated voltage sensing device to confirm that the device, the chassis, and the auxiliary circuits are de-energized.
- Install safety barriers and display a danger sign.
- During the tests, it is strictly forbidden for anyone to touch the device, the chassis, or the conductors while voltage is applied.
- Before turning on power to this equipment, check that all connections are made with the correct tightening torque and the device is off (open position).
- Before turning on power to this equipment, put all devices, doors, and covers back in place.
- Before turning on power to this equipment, beware of potential hazards and carefully inspect the work area for tools and objects that may have been left inside the equipment.

Failure to follow these instructions will result in death or serious injury.

Procedure Definition

Procedure characteristics	Description
Action	<ul style="list-style-type: none"> • Check closing the device with the MN undervoltage release at U_n. • Check opening the device with the MN undervoltage release below $0.7 U_n$. • Check closing the device with the MN undervoltage release above $0.35 U_n$.
Goal	Verify device operation when equipped with an MN undervoltage release operating.
Frequency	Refer to Recommended Frequency for the Intermediate End-User Maintenance Program, page 15.
Special indications	<ul style="list-style-type: none"> • Connect the MN undervoltage release to an external power supply. • With an MNR delayed undervoltage release, disconnect the MN delay unit.
Necessary tools	<ul style="list-style-type: none"> • Adjustable external power supply • Voltmeter • External switch
Related documents, page 6	<ul style="list-style-type: none"> • <i>MasterPacT MTZ1 IEC Circuit Breakers with MicroLogic Active Control Unit - User Guide</i> • <i>MasterPacT MTZ2/MTZ3 IEC Circuit Breakers with MicroLogic Active Control Unit - User Guide</i> • <i>MasterPacT MTZ1/MTZ2/MTZ3 - MN-MX-XF Voltage Releases - Instruction Sheet</i>

Preliminary Conditions

The device must comply with the conditions specified below. Refer to the *MasterPacT MTZ User Guides* to find instructions for operating the device.

Device installation type	Position of poles	Mechanism	Device position in the chassis
Fixed	Open	Charged	N/A
Drawout	Open	Charged	Test

MN Undervoltage Release Wiring Diagram

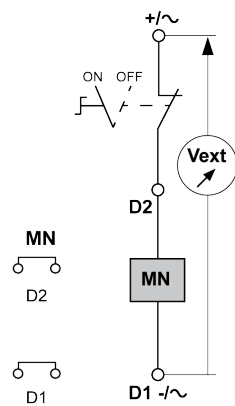

MN Undervoltage Release Operating Mode

- MasterPacT MTZ device status with an MN undervoltage release during voltage drop:

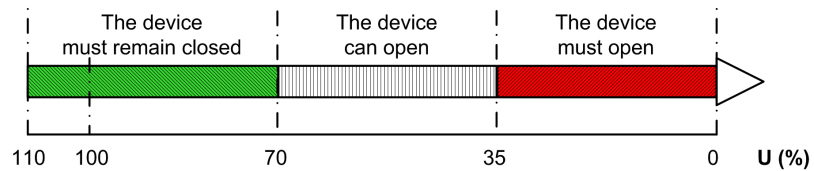

- MasterPacT MTZ device status with an MN undervoltage release during voltage increase:

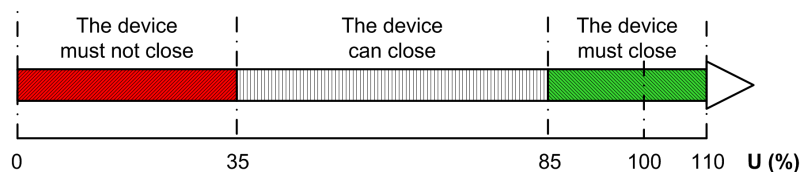

Closing and Opening Procedures with the MN Undervoltage Release

⚠️⚠️ DANGER

HAZARD OF ELECTRIC SHOCK

When using the adjustable external power supply, take all suitable measures to protect against electric shock.

Failure to follow these instructions will result in death or serious injury.

Before starting this check, it is advisable to execute a few electrical opening and closing cycles as per procedure Mechanism NII_ZA_1, page 28.

Step	Action	Corrective action
1	Disconnect supply wires on the customer terminal block.	
2	Connect the external switch and the adjustable external power supply according to the wiring diagram above.	
3	Set the external power supply voltage to U_n .	
4	Close the external switch.	
5	Press the closing pushbutton. The device closes.	<p>If the device does not close:</p> <ol style="list-style-type: none"> 1. Check that the power supply voltage is set to U_n and do the procedure again. 2. If the device still does not close, replace the MN undervoltage release (refer to <i>MasterPacT MTZ1/MTZ2/MTZ3 - MN-MX-XF Voltage Releases - Instruction Sheet</i>). <p>If the problem persists, contact your Schneider Electric Services representative.</p>
6	Gradually decrease the voltage: <ul style="list-style-type: none"> • The device can open at any voltage between $0.7 U_n$ and $0.35 U_n$. • The device must open at $0.35 U_n$. • The device must remain open below $0.35 U_n$. 	<ul style="list-style-type: none"> • If the device opens before the voltage reaches $0.7 U_n$, replace the MN undervoltage release. • If the device does not open below $0.35 U_n$, replace the MN undervoltage release. • If the device does not remain open below $0.35 U_n$, replace the MN undervoltage release. <p>Refer to <i>MasterPacT MTZ1/MTZ2/MTZ3 - MN-MX-XF Voltage Releases - Instruction Sheet</i> to replace the MN undervoltage release.</p> <p>If the problem persists, contact your Schneider Electric Services representative.</p>
7	Set the voltage to a value lower than $0.35 U_n$.	
8	Charge the mechanism.	
9	Press the closing pushbutton. The device must not close.	<p>If the device closes:</p> <ol style="list-style-type: none"> 1. Check that the power supply voltage is set to a value lower than $0.35 U_n$ and do the procedure again. 2. If the device still closes, replace the MN undervoltage release (refer to <i>MasterPacT MTZ1/MTZ2/MTZ3 - MN-MX-XF Voltage Releases - Instruction Sheet</i>). <p>If the problem persists, contact your Schneider Electric Services representative.</p>
10	Gradually increase the voltage. While pressing the closing pushbutton: <ul style="list-style-type: none"> • The device can close at any voltage between $0.35 U_n$ and $0.85 U_n$. • The device must close at $0.85 U_n$. • The device must remain closed above $0.85 U_n$. 	<ul style="list-style-type: none"> • If the device does not close at $0.85 U_n$, replace the MN undervoltage release (refer to <i>MasterPacT MTZ1/MTZ2/MTZ3 - MN-MX-XF Voltage Releases - Instruction Sheet</i>). • If the device does not remain closed above $0.85 U_n$, replace the MN undervoltage release (refer to <i>MasterPacT MTZ1/MTZ2/MTZ3 - MN-MX-XF Voltage Releases - Instruction Sheet</i>). <p>If the problem persists, contact your Schneider Electric Services representative.</p>

Step	Action	Corrective action
11	Reconnect the customer terminal block according to the initial wiring.	
12	Check that the device electrically closes and opens according to procedure Mechanism NII_ZA_1, page 28.	

Auxiliaries NIII_ZA_5: Check Time Delay of MNR Delayed Undervoltage Release

Safety Instructions

⚠️⚠️ DANGER

HAZARD OF ELECTRIC SHOCK, EXPLOSION, OR ARC FLASH

- Apply appropriate personal protective equipment (PPE) and follow safe electrical work practices. See NFPA 70E, CSA Z462, NOM 029-STPS, or local equivalent.
- This equipment must only be installed and serviced by qualified electrical personnel.
- Unless specified otherwise in the maintenance procedures, all operations (inspection, test, and preventive maintenance) must be carried out with the device, the chassis, and the auxiliary circuits de-energized.
- Check that the device and the chassis are de-energized on the upstream and downstream terminals.
- Always use a properly rated voltage sensing device to confirm that the device, the chassis, and the auxiliary circuits are de-energized.
- Install safety barriers and display a danger sign.
- During the tests, it is strictly forbidden for anyone to touch the device, the chassis, or the conductors while voltage is applied.
- Before turning on power to this equipment, check that all connections are made with the correct tightening torque and the device is off (open position).
- Before turning on power to this equipment, put all devices, doors, and covers back in place.
- Before turning on power to this equipment, beware of potential hazards and carefully inspect the work area for tools and objects that may have been left inside the equipment.

Failure to follow these instructions will result in death or serious injury.

Procedure Definition

Procedure characteristics	Description
Action	Check the time delay on the MN delay unit at 0.35 Un and 0.7 Un.
Goal	Verify that the MNR delayed undervoltage release is not activated before the end of the selected time delay.
Frequency	Refer to Recommended Frequency for the Intermediate End-User Maintenance Program, page 15.
Special indications	Connect the MNR delayed undervoltage release to an external power supply.
Necessary tools	<ul style="list-style-type: none"> • Adjustable external power supply • Voltmeter • Stopwatch
Related documents, page 6	<ul style="list-style-type: none"> • <i>MasterPacT MTZ1 IEC Circuit Breakers with MicroLogic Active Control Unit - User Guide</i> • <i>MasterPacT MTZ2/MTZ3 IEC Circuit Breakers with MicroLogic Active Control Unit - User Guide</i> • <i>MasterPacT MTZ1/MTZ2/MTZ3 - MN-MX-XF Voltage Releases - Instruction Sheet</i>

Preliminary Conditions

The device must comply with the conditions specified below. Refer to the *MasterPacT MTZ User Guides* to find instructions for operating the device.

Device installation type	Position of poles	Mechanism	Device position in the chassis
Fixed	Closed	Discharged	N/A
Drawout	Closed	Discharged	Test

Time Delay Definition

The time delay is the time elapsed between the opening order and the moment when the MNR delayed undervoltage release operates.

The time delay does not exceed the delay setting $\pm 15\%$.

MNR Delayed Undervoltage Release Wiring Diagram

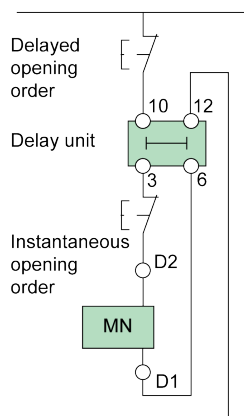

Checking the Time Delay of the MN Delay Unit During Device Opening

⚡⚠ DANGER

HAZARD OF ELECTRIC SHOCK

When using the adjustable external power supply, take all suitable measures to protect against electric shock.

Failure to follow these instructions will result in death or serious injury.

Before starting this check, it is advised to execute a few electrical opening and closing cycles as per procedure Mechanism NII_ZA_1, page 28.

Step	Action	Corrective action
1	Disconnect supply wires on the customer terminal block.	
2	Connect the adjustable external power supply according to the corresponding wiring diagram above.	

Step	Action	Corrective action
	NOTE: If possible, the opening time should be measured using the main connections. If that is not possible, carry out the measurement on an OF contact.	
3	Set the external power supply voltage to 0.35 Un.	
4	To start the stopwatch, remove the power supply or issue a delayed opening order.	
5	The device opens when the time delay equals the delay setting on the MN delay unit. The stopwatch stops when the device opens.	
6	Check the time delay on the stopwatch: it must equal the delay setting $\pm 15\%$.	If the time delay differs by more than $\pm 15\%$ from the delay unit setting, replace the MN delay unit (refer to <i>MasterPacT MTZ1/MTZ2/MTZ3 - MN-MX-XF Voltage Releases - Instruction Sheet</i>) and do the procedure again. If the problem persists, contact your Schneider Electric Services representative.
7	Reconnect the external power supply to the MNR delayed undervoltage release, and then close the device.	
8	Set the external power supply voltage to 0.7 Un.	
9	To start the stopwatch, remove the power supply or issue a delayed opening order.	
10	The device opens when the time delay equals the delay setting on the MN delay unit. The stopwatch stops when the device opens.	
11	Check the time delay on the stopwatch: it must equal the delay setting $\pm 15\%$.	If the time delay differs by more than $\pm 15\%$ from the delay unit setting, replace the MN delay unit (refer to <i>MasterPacT MTZ1/MTZ2/MTZ3 - MN-MX-XF Voltage Releases - Instruction Sheet</i>) and do the procedure again. If the problem persists, contact your Schneider Electric Services representative.
12	Reconnect the customer terminal block according to the initial wiring.	
13	Check that the device electrically closes and opens according to procedure Mechanism NII_ZA_1, page 28.	

Control Unit NIII_ZA_3: Save Protection Settings, Reports, and Event Logs With EcoStruxure Power Commission Software

Safety Instructions

⚡⚠ DANGER

HAZARD OF ELECTRIC SHOCK, EXPLOSION, OR ARC FLASH

- Apply appropriate personal protective equipment (PPE) and follow safe electrical work practices. See NFPA 70E, CSA Z462, NOM 029-STPS, or local equivalent.
- This equipment must only be installed and serviced by qualified electrical personnel.
- Unless specified otherwise in the maintenance procedures, all operations (inspection, test, and preventive maintenance) must be carried out with the device, the chassis, and the auxiliary circuits de-energized.
- Check that the device and the chassis are de-energized on the upstream and downstream terminals.
- Always use a properly rated voltage sensing device to confirm that the device, the chassis, and the auxiliary circuits are de-energized.
- Install safety barriers and display a danger sign.
- During the tests, it is strictly forbidden for anyone to touch the device, the chassis, or the conductors while voltage is applied.
- Before turning on power to this equipment, check that all connections are made with the correct tightening torque and the device is off (open position).
- Before turning on power to this equipment, put all devices, doors, and covers back in place.
- Before turning on power to this equipment, beware of potential hazards and carefully inspect the work area for tools and objects that may have been left inside the equipment.

Failure to follow these instructions will result in death or serious injury.

Procedure Definition

Procedure characteristics	Description
Action	Save project information by using EcoStruxure Power Commission software installed on a PC: <ul style="list-style-type: none"> • Save the protection settings of the MicroLogic Active control unit • Generate and save project report • Export and save event logs of the MicroLogic Active control unit.
Goal	Verify that the protection settings in EcoStruxure Power Commission software are up-to-date with the ones in the MicroLogic Active control unit, and back-up project information (project reports and event logs).
Frequency	Refer to Recommended Frequency for the Intermediate End-User Maintenance Program, page 14.
Special indications	–
Necessary tools	<ul style="list-style-type: none"> • A PC running EcoStruxure Power Commission software. • A USB-A to USB-C cable (RS PRO, reference: 251-3298)
Related documents, page 6	<ul style="list-style-type: none"> • <i>MasterPacT MTZ - MicroLogic Active Control Unit - User Guide</i> • <i>EcoStruxure Power Commission Online Help</i>

Preliminary Conditions

The device must comply with the conditions specified below. Refer to the *MasterPacT MTZ User Guides* to find instructions for operating the device.

Device installation type	Position of poles	Mechanism	Device position in the chassis
Fixed	Open or Closed	Charged or Discharged	N/A
Drawout	Open or Closed	Charged or Discharged	Connected or Test or Disconnected

Saving Protection Settings of MicroLogic Active Control Unit

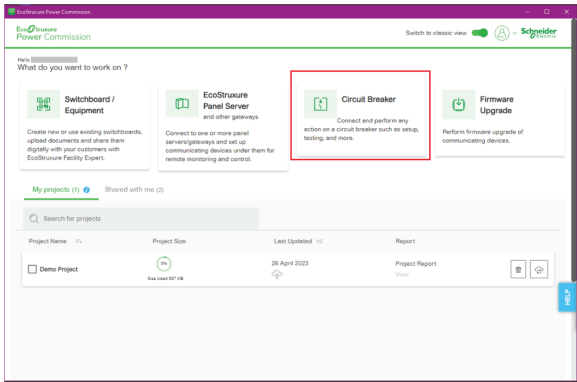
Step	Action	Corrective action
1	<p>Connect a PC running EcoStruxure Power Commission software to the MicroLogic Active control unit.</p>  <p>A Cable plug connected to the USB-C port of MicroLogic Active control unit B USB-A to USB-C port cable C PC running EcoStruxure Power Commission software</p>	
2	Launch EcoStruxure Power Commission software.	
3	<p>From the EcoStruxure Power Commission home page, click the Circuit Breaker section.</p> 	<p>If EcoStruxure Power Commission software does not connect to the MicroLogic Active control unit:</p> <ol style="list-style-type: none"> 1. Replace the USB cable. 2. Connect the PC to the MicroLogic Active control unit again. 3. If the problem persists, contact your Schneider Electric Services representative. <p>It disappears automatically when the device is discovered.</p>
4	<p>Click CONNECT on the displayed pop-up screen, to add the device to the switchboard and connect to it.</p> <p>Result: A window displays to indicate that device connection is in progress. It disappears automatically when the device is connected.</p>	

Step	Action	Corrective action
5	Enter the account details when prompted.	
6	Click the Configure section. 	
7	The Protection tab displays the protection settings: <ul style="list-style-type: none"> The project settings currently saved in EcoStruxure Power Commission software are displayed under the Protection tab. The device settings are displayed on the right hand-side of the screen. Discrepancies in the protection settings between the project in EcoStruxure Power Commission software and the device are highlighted in yellow.	
8	Click the WRITE TO PROJECT button at top of the screen.	
9	EcoStruxure Power Commission software downloads the existing protection settings from the MicroLogic Active control unit of the selected device. A message displays when writing to the project has completed successfully. Click OK .	
10	Click the Save icon at the top of the EcoStruxure Power Commission window to save the project, including the protection settings.	

Generating Project Reports

Step	Action	Corrective action
1	At the top of the EcoStruxure Power Commission window, click Reports > Project Report . Result: EcoStruxure Power Commission software generates a project report for one or more devices concerned.	
2	A window opens and displays the complete report of the project, that is, comprehensive project information.	
3	You can download the report on the PC or print it.	
4	Close the report and return to the device listing.	
5	Click the Save icon at the top of the EcoStruxure Power Commission window to save the project.	
6	A message displays when project saving has completed successfully. Click OK .	
7	Close the report and return to the device screen.	

Exporting Event Logs

Step	Action	Corrective action
1	In EcoStruxure Power Commission software, navigate to the SWITCHBOARD VIEW window.	
2	Click the Device Check Up section.	
3	Click the Logs tab to view the event log reports which help you to ensure that the installed equipment is operating correctly as per the settings.	
4	Click the EXPORT button.	

Step	Action	Corrective action
5	A window opens and displays the event log export. Event log exports must be open with a spreadsheet software.	
6	You can download the event log export on the PC or print it.	
7	Return to the SWITCHBOARD VIEW window.	
8	Click the red button DISCONNECT to disconnect from the device.	
9	Exit EcoStruxure Power Commission software.	

Control Unit NIII_ZA_4: Check Overcurrent Protection

Safety Instructions

 **DANGER**

HAZARD OF ELECTRIC SHOCK, EXPLOSION, OR ARC FLASH

- Apply appropriate personal protective equipment (PPE) and follow safe electrical work practices. See NFPA 70E, CSA Z462, NOM 029-STPS, or local equivalent.
- This equipment must only be installed and serviced by qualified electrical personnel.
- Unless specified otherwise in the maintenance procedures, all operations (inspection, test, and preventive maintenance) must be carried out with the device, the chassis, and the auxiliary circuits de-energized.
- Check that the device and the chassis are de-energized on the upstream and downstream terminals.
- Always use a properly rated voltage sensing device to confirm that the device, the chassis, and the auxiliary circuits are de-energized.
- Install safety barriers and display a danger sign.
- During the tests, it is strictly forbidden for anyone to touch the device, the chassis, or the conductors while voltage is applied.
- Before turning on power to this equipment, check that all connections are made with the correct tightening torque and the device is off (open position).
- Before turning on power to this equipment, put all devices, doors, and covers back in place.
- Before turning on power to this equipment, beware of potential hazards and carefully inspect the work area for tools and objects that may have been left inside the equipment.

Failure to follow these instructions will result in death or serious injury.

Procedure Definition

Procedure characteristics	Description
Action	<ul style="list-style-type: none"> • Check overcurrent protection (long-time, short-time, instantaneous) by using EcoStruxure Power Commission software installed on a PC. • Check fault-trip LEDs. • Save the test results to a personal computer.
Goal	Verify that the control unit operates when any electrical fault occurs.
Frequency	Refer to Recommended Frequency for the Intermediate End-User Maintenance Program, page 15.
Special indications	–
Necessary tools	<ul style="list-style-type: none"> • A PC running EcoStruxure Power Commission software • A USB-A to USB-C cable (RS PRO, reference: 251-3298)
Related documents, page 6	<ul style="list-style-type: none"> • <i>MasterPacT MTZ1 IEC Circuit Breakers with MicroLogic Active Control Unit - User Guide</i> • <i>MasterPacT MTZ2/MTZ3 IEC Circuit Breakers with MicroLogic Active Control Unit - User Guide</i> • <i>MasterPacT MTZ - MicroLogic Active Control Unit - User Guide</i> • <i>EcoStruxure Power Commission Online Help</i>

Preliminary Conditions

The device must comply with the conditions specified below. Refer to the *MasterPacT MTZ User Guides* to find instructions for operating the device.

Device installation type	Position of poles	Mechanism	Device position in the chassis
Fixed	Closed	Discharged	N/A
Drawout	Closed	Discharged	Test

Checking Overcurrent Protection and Fault-Trip LEDs

The process of checking overcurrent protection includes the following procedures:

- Connect to the MicroLogic Active control unit with EcoStruxure Power Commission software, page 121.
- Launch an automatic trip curve test with preconfigured test points, page 122.
- Launch an automatic trip curve test with custom test points, page 125.

Connecting the MicroLogic Active Control Unit to EcoStruxure Power Commission Software

Step	Action
1	If the device is equipped with an MN undervoltage release, either connect it to the power supply with its rated voltage or remove the MN undervoltage release.
2	<p>Connect a PC running EcoStruxure Power Commission software to the MicroLogic Active control unit.</p>  <p>A Cable plug connected to the USB-C port of MicroLogic Active control unit</p> <p>B USB-A to USB-C port cable</p> <p>C PC running EcoStruxure Power Commission software</p>
3	Launch EcoStruxure Power Commission software.

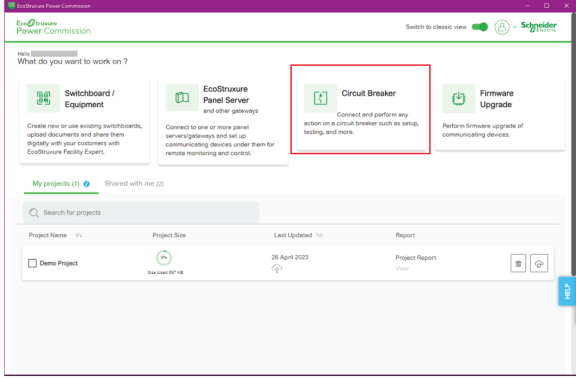
Step	Action
4	<p>From the EcoStruxure Power Commission home page, click the Circuit Breaker section.</p> 
5	<p>Click CONNECT on the displayed pop-up screen, to add the device to the switchboard and connect to it.</p> <p>Result: A window displays to indicate that device connection is in progress. It disappears automatically when the device is connected.</p>
6	Enter the account details when prompted.
7	In the Device Check Up section, click the Device tab.
8	Follow the procedure Control Unit NII_ZA_3, page 116 to save settings and the waveform capture to avoid losing this information.
9	Click the Automatic Trip Curve Test section.

Launching Automatic Trip Curve Test with Preconfigured Test Points

NOTICE

HAZARD OF UNEXPECTED BEHAVIOR

Before launching the automatic trip curve test, make a note of the active trip curve setting (Standard or ERMS) and set the circuit breaker to this trip curve at the end of the test.

Failure to follow these instructions can result in incorrect settings.

Do the procedure for each of the following overcurrent protection functions:



- Long-time I_r
- Short-time I_{sd} (MicroLogic Active 5.0 and 6.0)
- Instantaneous I_i
- Ground-fault I_g (MicroLogic Active 6.0)

The following trip curves can be tested:

- Standard
- ERMS

After connecting the PC running EcoStruxure Power Commission software to the MicroLogic Active control unit, page 121, follow this procedure to test overcurrent protection using preconfigured test points:

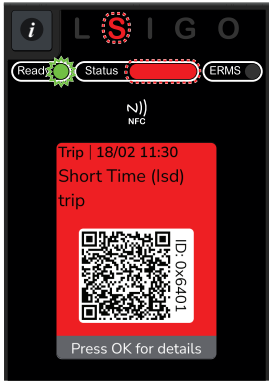

1	<p>Select Preconfigured test point.</p> <p>Result: EcoStruxure Power Commission software displays the lists of curves and overcurrent protection functions available on the MicroLogic Active control unit.</p>	
2	<p>Select the trip curve and overcurrent protection to be tested. By default Standard trip curve and all the protection functions are selected. You can select one or more trip curves to test.</p>	
3	<p>Check that the device is closed, the fault-trip LEDs are off, and the Status bar is green.</p>	
4	<p>Click RUN TEST.</p>	
5	<p>Read carefully the safety message that displays and click I UNDERSTAND.</p>	
6	<p>Follow the prompts to engage or disengage ERMS, or close the circuit breaker.</p> <p>Result: The automatic trip test starts executing.</p>	
7	<p>Check that the device trips.</p>	<p>If the device does not trip:</p> <ol style="list-style-type: none"> 1. Check that the device is closed. 2. Check that the blue fault-trip reset button is pushed-in. Refer to troubleshooting in the appendix, page 155. 3. Do the procedure again. <p>If the problem persists, contact your Schneider Electric Services representative.</p>

<p>8</p>	<p>Check that the trip cause LED corresponding to the protection tested is on and the MicroLogic Active screen display turns to red with the correct trip message.</p> <p>Example: S trip cause LED is blinking red when short-time protection is tested.</p> 	
<p>9</p>	<p>Check in EcoStruxure Power Commission software that the test is successful.</p>	<ul style="list-style-type: none"> • If the test is successful, reset the thermal memory then continue the next test. • If the test fails, reset the thermal memory then redo the test. If the problem persists, contact your Schneider Electric Services representative.
<p>10</p>	<p>Before proceeding to the next protection setting, EcoStruxure Power Commission software prompts you to:</p> <ul style="list-style-type: none"> • Reset the trip cause LEDs by pressing and holding the  button on the MicroLogic Active control unit for more than 3 seconds. • Reset the device by pressing the blue fault-trip reset button on the front cover. • Close the device. 	
<p>11</p>	<p>Click CONFIRM.</p> <p>Result: EcoStruxure Power Commission software proceeds to perform the next overcurrent protection test.</p>	
<p>12</p>	<p>If you have selected more than one trip curve to test, you are prompted to switch to another trip curve to continue the tests. Press CONFIRM when you are ready to continue.</p> <p>Result: The next trip curve test begins.</p>	
<p>13</p>	<p>After completing the automatic trip curve tests, set the circuit breaker to the active trip curve noted before starting the tests.</p>	

Launching Automatic Trip Curve Test with Custom Test Points

After connecting the PC running EcoStruxure Power Commission software to the MicroLogic Active control unit, page 121, follow this procedure to test overcurrent protection functions using custom test points. For phase overcurrent, up to six test points can be added. For ground-fault, only one test point can be tested.

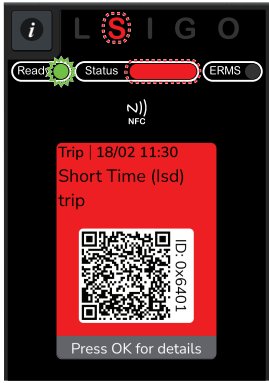
1	Select Custom test point .																										
2	<p>Add test points as required and define the injection current and time for each test point.</p> <p>Automatic Trip Curve test</p> <p><input type="radio"/> Preconfigured test point</p> <p><input checked="" type="radio"/> Custom test point</p> <p>Select the test you want to perform on the device: The tests would be performed consecutively.</p> <p><input checked="" type="checkbox"/> Phase overcurrent protection</p> <table border="1" data-bbox="363 808 911 992"> <thead> <tr> <th></th> <th>Injection current</th> <th></th> <th>Injection time</th> <th></th> </tr> </thead> <tbody> <tr> <td><input checked="" type="checkbox"/></td> <td>1576</td> <td>A</td> <td>30</td> <td>s</td> </tr> <tr> <td><input checked="" type="checkbox"/></td> <td>2641</td> <td>A</td> <td>2</td> <td>s</td> </tr> <tr> <td><input checked="" type="checkbox"/></td> <td>4000</td> <td>A</td> <td>1</td> <td>s</td> </tr> <tr> <td><input checked="" type="checkbox"/></td> <td>160</td> <td>A</td> <td>0.01</td> <td>s</td> </tr> </tbody> </table> <p><input type="button" value="Add test point"/></p> <p><input type="button" value="RUN TEST"/> Make sure that the protection type is available on the device.</p>		Injection current		Injection time		<input checked="" type="checkbox"/>	1576	A	30	s	<input checked="" type="checkbox"/>	2641	A	2	s	<input checked="" type="checkbox"/>	4000	A	1	s	<input checked="" type="checkbox"/>	160	A	0.01	s	
	Injection current		Injection time																								
<input checked="" type="checkbox"/>	1576	A	30	s																							
<input checked="" type="checkbox"/>	2641	A	2	s																							
<input checked="" type="checkbox"/>	4000	A	1	s																							
<input checked="" type="checkbox"/>	160	A	0.01	s																							
3	Check that the device is closed, the fault-trip LEDs are off, and the Status bar is green.																										
4	Click RUN TEST .																										
5	Read carefully the safety message that displays and click I UNDERSTAND .																										
6	<p>Follow the prompts to engage or disengage ERMS, or close the circuit breaker.</p> <p>Result: The automatic trip test starts executing.</p>																										
7	<p>Check that the device trips.</p> <p>NOTE: For certain custom test points, based on the injection current and time, a No Trip result may be acceptable. Check the final report for detailed information regarding a No Trip result.</p>	<p>If the device does not trip (for test points where a trip is expected):</p> <ol style="list-style-type: none"> 1. Check that the device is closed. 2. Check that the blue fault-trip reset button is pushed-in. Refer to troubleshooting in the appendix, page 155. 3. Do the procedure again. <p>If the problem persists, contact your Schneider Electric Services representative.</p>																									

<p>8</p>	<p>Check that the trip cause LED corresponding to the protection tested is on and the MicroLogic Active screen display turns to red with the correct trip message.</p> <p>Example: S trip cause LED is blinking red when short-time protection is tested.</p> 	
<p>9</p>	<p>Check in EcoStruxure Power Commission software that the test is successful.</p>	<ul style="list-style-type: none"> • If the test is successful, reset the thermal memory then continue the next test. • If the test fails, reset the thermal memory then redo the test. If the problem persists, contact your Schneider Electric Services representative. <p>NOTE: If EcoStruxure Power Commission software displays a No trip result, check the corresponding threshold and time settings of the circuit breaker to determine if a trip was expected for the values entered. A No Trip result may be acceptable if the user-defined values are below the configured settings of the circuit breaker.</p>
<p>10</p>	<p>Before proceeding to the next protection setting, EcoStruxure Power Commission software prompts you to:</p> <ul style="list-style-type: none"> • Reset the trip cause LEDs by pressing and holding the  button on the MicroLogic Active control unit for more than 3 seconds. • Reset the device by pressing the blue fault-trip reset button on the front cover. • Close the device. 	
<p>11</p>	<p>Click CONFIRM.</p> <p>Result: EcoStruxure Power Commission software proceeds to perform the next overcurrent protection test.</p>	

Saving the Test Results to a PC

After running the overcurrent protection tests, access the test results in EcoStruxure Power Commission software.

Step	Action
1	At the top of the EcoStruxure Power Commission window, click Reports > Automatic Trip Test Report for MasterPacT MTZ. A window opens and displays the report.
2	Save the report on the PC and print it, if needed.
3	Exit EcoStruxure Power Commission software.

Customer Report

Add the automatic trip test report generated above to the customer report.

Chassis NIII_ZA_1: Check Operation of CD, CT, CE Position Contacts and EF Auxiliary Contacts

Safety Instructions

⚠️⚠️ DANGER

HAZARD OF ELECTRIC SHOCK, EXPLOSION, OR ARC FLASH

- Apply appropriate personal protective equipment (PPE) and follow safe electrical work practices. See NFPA 70E, CSA Z462, NOM 029-STPS, or local equivalent.
- This equipment must only be installed and serviced by qualified electrical personnel.
- Unless specified otherwise in the maintenance procedures, all operations (inspection, test, and preventive maintenance) must be carried out with the device, the chassis, and the auxiliary circuits de-energized.
- Check that the device and the chassis are de-energized on the upstream and downstream terminals.
- Always use a properly rated voltage sensing device to confirm that the device, the chassis, and the auxiliary circuits are de-energized.
- Install safety barriers and display a danger sign.
- During the tests, it is strictly forbidden for anyone to touch the device, the chassis, or the conductors while voltage is applied.
- Before turning on power to this equipment, check that all connections are made with the correct tightening torque and the device is off (open position).
- Before turning on power to this equipment, put all devices, doors, and covers back in place.
- Before turning on power to this equipment, beware of potential hazards and carefully inspect the work area for tools and objects that may have been left inside the equipment.

Failure to follow these instructions will result in death or serious injury.

Procedure Definition

Procedure characteristics	Description
Action	Operate the chassis position contacts: <ul style="list-style-type: none"> • CD disconnected position contact • CT test position contact • CE connected position contact • EF combined connected/closed auxiliary contact (MasterPacT MTZ2/MTZ3)
Goal	Verify consistency between actual position of the device in the chassis and the indications given by the position contacts.
Frequency	Refer to Recommended Frequency for the Intermediate End-User Maintenance Program, page 14.
Special indications	<ul style="list-style-type: none"> • If the device positions in the chassis are indicated on the front panel of the switchboard, make sure that the auxiliary circuits are energized. • If the device positions in the chassis are not indicated on the front panel of the switchboard, isolate the auxiliary circuits and use an ohmmeter or a tester to test them.

Procedure characteristics	Description
Necessary tools	Ohmmeter or tester
Related documents, page 6	<ul style="list-style-type: none"> MasterPacT MTZ1 IEC Circuit Breakers with MicroLogic Active Control Unit - User Guide MasterPacT MTZ2/MTZ3 IEC Circuit Breakers with MicroLogic Active Control Unit - User Guide MasterPacT MTZ1/MTZ2/MTZ3 - Position Contacts (Connected / Disconnected / Test) - Instruction Sheet MasterPacT MTZ2/MTZ3 - EF Combined Connected/Closed Contact - Instruction Sheet

Preliminary Conditions

The device must comply with the conditions specified below. Refer to the *MasterPacT MTZ User Guides* to find instructions for operating the device.

Device installation type	Position of poles	Mechanism	Device position in the chassis
Fixed	N/A	N/A	N/A
Drawout	Open	Discharged	Disconnected NOTE: It is advisable to check the positions with the device in the chassis to obtain the correct position of the actuators.

Location of Contacts in the MasterPacT MTZ1 Devices

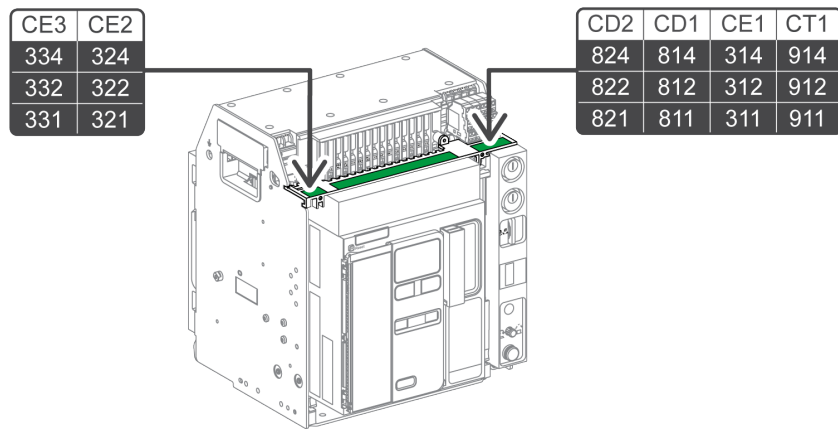

Location of Contacts in the MasterPacT MTZ2/MTZ3 Devices

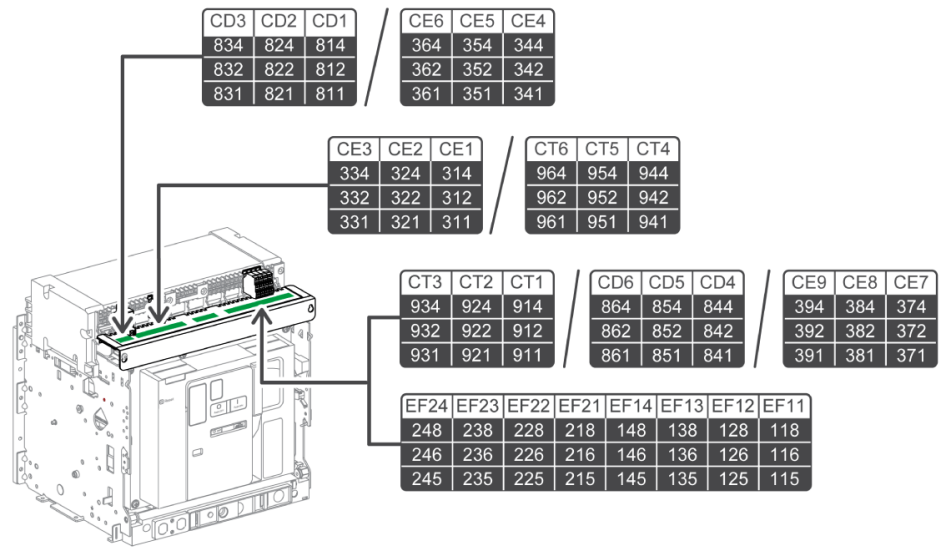

Wiring Diagrams of CD, CT, and CE Position Contacts

The following wiring diagrams show the case of a MasterPacT MTZ2/MTZ3 chassis with three CD, three CT, and three CE contacts, that is, the standard configuration. The checking operations are based on this configuration. The availability of the position contacts depends on the customer configuration.

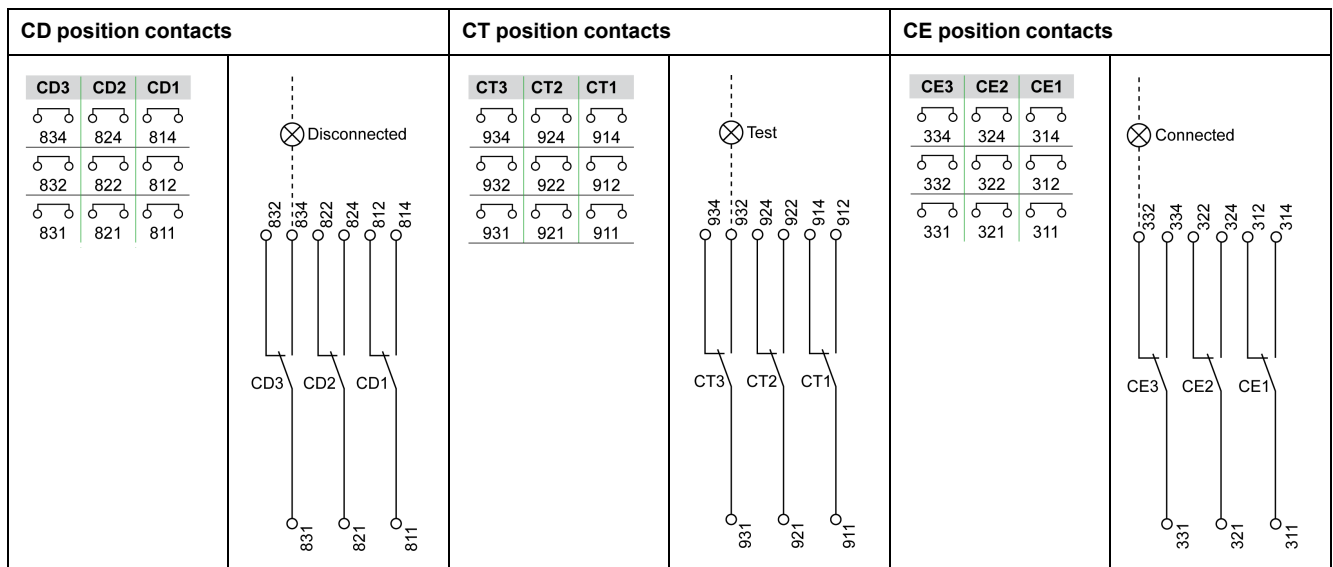

Checking Position Contacts With Device in Disconnected Position

The CD position contacts indicate that the device is in the disconnected position.

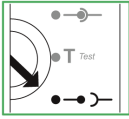
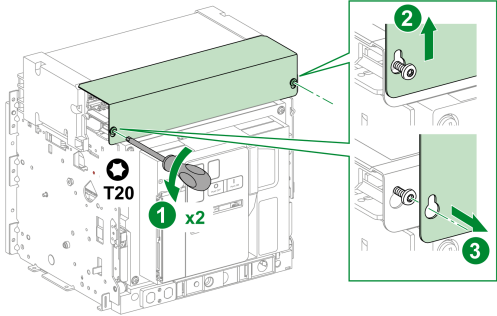
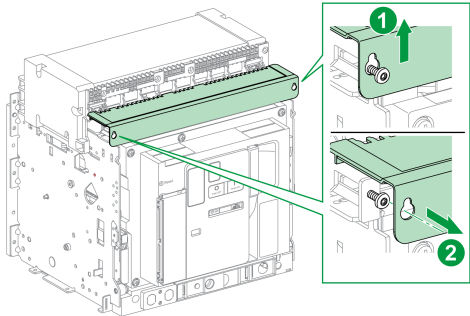
Step	Action	Corrective action
1	<p>Check that the device is in the disconnected position.</p>  <p>NOTE: If needed, refer to device racking operations as per procedure Chassis NII_ZA_1, page 61.</p>	
2	<p>Check that the signal is consistent with the device position by using the LED on the switchboard, if any.</p>	<p>If the LED on the switchboard does not operate, check the LED and the voltage power supply.</p>
3	<p>Remove the auxiliary terminal shield from a drawout device, if present.</p> 	
4	<p>For a MasterPacT MTZ2/MTZ3 device, remove the terminal block identification plate.</p> 	
5	<p>Identify and disconnect all wires for the CD, CT, and CE position contacts, and EF auxiliary contacts, if present.</p>	
6	<p>For MasterPacT MTZ1, use an ohmmeter or tester:</p> <ul style="list-style-type: none"> • To check electrical continuity between terminals: <ul style="list-style-type: none"> ◦ 811-814 on CD1 contact. ◦ 821-824 on CD2 contact. • To check electrical non-continuity between terminals: <ul style="list-style-type: none"> ◦ 911-912 on CT1 contact. ◦ 311-314 on CE1 contact. ◦ 321-324 on CE2 contact. ◦ 331-334 on CE3 contact. <p>For MasterPacT MTZ2/MTZ3, use an ohmmeter or tester:</p> <ul style="list-style-type: none"> • To check electrical continuity between terminals: <ul style="list-style-type: none"> ◦ 811-814 on CD1 contact. ◦ 821-824 on CD2 contact. ◦ 831-834 on CD3 contact. • To check electrical non-continuity between terminals: <ul style="list-style-type: none"> ◦ 911-912 on CT1 contact. ◦ 921-922 on CT2 contact. ◦ 931-932 on CT3 contact. ◦ 311-314 on CE1 contact. ◦ 321-324 on CE2 contact. ◦ 331-334 on CE3 contact. 	<p>If a contact does not operate:</p> <ol style="list-style-type: none"> 1. Check the fixing of the CD contact actuator and manually operate it (refer to <i>MasterPacT MTZ1/MTZ2/MTZ3 - Position Contacts (Connected / Disconnected / Test) - Instruction Sheet</i>). 2. Check contact status again. 3. If the contact still does not operate, replace the auxiliary terminal block (refer to <i>MasterPacT MTZ1/MTZ2/MTZ3 - Position Contacts (Connected / Disconnected / Test) - Instruction Sheet</i>). <p>If the problem persists, contact your Schneider Electric Services representative.</p>

Step	Action	Corrective action
7	If the device has other CD contact blocks, check the corresponding contacts.	
8	Put the device in the test position.	

Checking Position Contacts With Device in Test Position

The CT position contacts indicate that the device is in the test position.

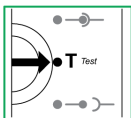
Step	Action	Corrective action
1	Check that the device is in the test position.  <p>NOTE: If needed, refer to device racking operations as per procedure Chassis NII_ZA_1, page 61.</p>	
2	Check that the signal is consistent with the device position by using the LED on the switchboard, if any.	If the LED on the switchboard does not operate, check the LED and the voltage power supply.
3	For MasterPacT MTZ1, use an ohmmeter or tester: <ul style="list-style-type: none"> • To check electrical continuity between terminals 911-912 on CT1 contact. • To check electrical non-continuity between terminals: <ul style="list-style-type: none"> ◦ 811-814 on CD1 contact. ◦ 821-824 on CD2 contact. ◦ 311-314 on CE1 contact. ◦ 321-324 on CE2 contact. ◦ 331-334 on CE3 contact. For MasterPacT MTZ2/MTZ3, use an ohmmeter or tester: <ul style="list-style-type: none"> • To check electrical continuity between terminals: <ul style="list-style-type: none"> ◦ 911-912 on CT1 contact. ◦ 921-922 on CT2 contact. ◦ 931-932 on CT3 contact. • To check electrical non-continuity between terminals: <ul style="list-style-type: none"> ◦ 811-814 on CD1 contact. ◦ 821-824 on CD2 contact. ◦ 831-834 on CD3 contact. ◦ 311-314 on CE1 contact. ◦ 321-324 on CE2 contact. ◦ 331-334 on CE3 contact. 	If a contact does not operate: <ol style="list-style-type: none"> 1. Check the fixing of the CT contact actuator and manually operate it (refer to <i>MasterPacT MTZ1/MTZ2/MTZ3 - Position Contacts (Connected / Disconnected / Test) - Instruction Sheet</i>). 2. Check contact status again. 3. If the contact still does not operate, replace the auxiliary terminal block (refer to <i>MasterPacT MTZ1/MTZ2/MTZ3 - Position Contacts (Connected / Disconnected / Test) - Instruction Sheet</i>). If the problem persists, contact your Schneider Electric Services representative.
4	If the device has other CT contact blocks, check the corresponding contacts.	
5	Put the device in the connected position.	

Checking Position Contacts With Device in Connected Position

The CE position contacts indicate that the device is in the connected position.

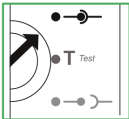
Step	Action	Corrective action
1	<p>Check that the device is in the connected position.</p>  <p>NOTE: If needed, refer to device racking operations as per procedure Chassis NIII_ZA_1, page 61.</p>	
2	Check that the signal is consistent with the device position by using the LED on the switchboard, if any.	If the LED on the switchboard does not operate, check the LED and the voltage power supply.
3	<p>For MasterPacT MTZ1, use an ohmmeter or tester:</p> <ul style="list-style-type: none"> • To check electrical continuity between terminals: <ul style="list-style-type: none"> ◦ 311-312 on CE1 contact. ◦ 321-322 on CE2 contact. ◦ 331-332 on CE3 contact. • To check electrical non-continuity between terminals: <ul style="list-style-type: none"> ◦ 811-814 on CD1 contact. ◦ 821-824 on CD2 contact. ◦ 911-912 on CT1 contact. <p>For MasterPacT MTZ2/MTZ3, use an ohmmeter or tester:</p> <ul style="list-style-type: none"> • To check electrical continuity between terminals: <ul style="list-style-type: none"> ◦ 311-312 on CE1 contact. ◦ 321-322 on CE2 contact. ◦ 331-332 on CE3 contact. • To check electrical non-continuity between terminals: <ul style="list-style-type: none"> ◦ 811-814 on CD1 contact. ◦ 821-824 on CD2 contact. ◦ 831-834 on CD3 contact. ◦ 911-912 on CT1 contact. ◦ 921-922 on CT2 contact. ◦ 931-932 on CT3 contact. 	<p>If a contact does not operate:</p> <ol style="list-style-type: none"> 1. Check the fixing of the CE contact actuator and manually operate it (refer to <i>MasterPacT MTZ1/MTZ2/MTZ3 - Position Contacts (Connected / Disconnected / Test) - Instruction Sheet</i>). 2. Check contact status again. 3. If the contact still does not operate, replace the auxiliary terminal block (refer to <i>MasterPacT MTZ1/MTZ2/MTZ3 - Position Contacts (Connected / Disconnected / Test) - Instruction Sheet</i>). <p>If the problem persists, contact your Schneider Electric Services representative.</p>
4	If the device has other CE contact blocks, check the corresponding contacts.	
5	Reconnect all the wires for the CD, CT, and CE position contacts.	
6	For MasterPacT MTZ2/MTZ3 with optional EF auxiliary contacts, check operation of these contacts, page 134.	
7	Put the terminal block identification plate and the auxiliary terminal shield back in place.	

Wiring Diagram of EF Auxiliary Contacts (Option on MasterPacT MTZ2/MTZ3)

The availability of the EF auxiliary contacts depends on the device.

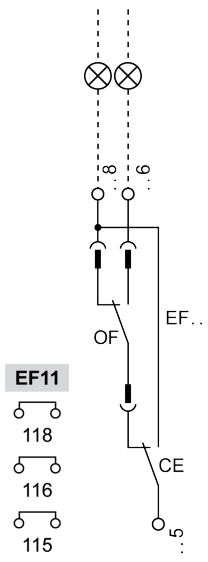

Checking Operation of EF Auxiliary Contacts (MasterPacT MTZ2/MTZ3)



DANGER

HAZARD OF ELECTRIC SHOCK, EXPLOSION, OR ARC FLASH

Check that the device and the chassis are de-energized on the upstream and downstream terminals.

Failure to follow these instructions will result in death or serious injury.

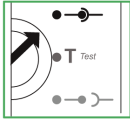
This EF information combines the device connected (CE) contact and device closed (OF) contact to produce the circuit connected/closed signal.

Step	Action	Corrective action
1	Put the device in the connected position. 	
2	Close the device.	
3	Check that the signal is consistent with the device position by using the LED on the switchboard, if any.	If the LED on the switchboard does not operate, check the LED and the voltage power supply.
4	With the device in the connected position and with poles closed, use an ohmmeter or tester: <ul style="list-style-type: none"> • To check electrical continuity between terminals 115-116. • To check electrical non-continuity between terminals 115-118. 	If a contact does not operate: <ol style="list-style-type: none"> 1. Put the device in the test position. 2. Check the fixing of the EF contact actuator and manually operate it (refer to <i>MasterPacT MTZ2/MTZ3 - EF Combined Connected/Closed Contact - Instruction Sheet</i>). 3. Check contact status again. 4. If the contact still does not operate, replace the EF contact (refer to <i>MasterPacT MTZ2/MTZ3 - EF Combined Connected/Closed Contact - Instruction Sheet</i>). 5. If there is still no improvement: <ul style="list-style-type: none"> • Check the operation of the OF indication contact as per procedure <i>Auxiliaries NIII_ZA_1</i>, page 99. • If necessary, replace the OF contact. If the problem persists, contact your Schneider Electric Services representative.
5	Open the device.	
6	With the device in the connected position and with poles open, use an ohmmeter or tester: <ul style="list-style-type: none"> • To check electrical continuity between terminals 115-118. • To check electrical non-continuity between terminals 115-116. 	
7	If the device has other EF auxiliary contact block, check them.	
8	Put the terminal block identification plate and the auxiliary terminal shield back in place.	

Chassis NIII_ZA_2: Check Operation of Safety Shutters

Safety Instructions

⚠️⚠️ DANGER

HAZARD OF ELECTRIC SHOCK, EXPLOSION, OR ARC FLASH

- Apply appropriate personal protective equipment (PPE) and follow safe electrical work practices. See NFPA 70E, CSA Z462, NOM 029-STPS, or local equivalent.
- This equipment must only be installed and serviced by qualified electrical personnel.
- Unless specified otherwise in the maintenance procedures, all operations (inspection, test, and preventive maintenance) must be carried out with the device, the chassis, and the auxiliary circuits de-energized.
- Check that the device and the chassis are de-energized on the upstream and downstream terminals.
- Always use a properly rated voltage sensing device to confirm that the device, the chassis, and the auxiliary circuits are de-energized.
- Install safety barriers and display a danger sign.
- During the tests, it is strictly forbidden for anyone to touch the device, the chassis, or the conductors while voltage is applied.
- Before turning on power to this equipment, check that all connections are made with the correct tightening torque and the device is off (open position).
- Before turning on power to this equipment, put all devices, doors, and covers back in place.
- Before turning on power to this equipment, beware of potential hazards and carefully inspect the work area for tools and objects that may have been left inside the equipment.

Failure to follow these instructions will result in death or serious injury.

⚠️ DANGER

HAZARD OF DEVICE FALLING

- Be sure that lifting equipment has lifting capacity for the device being lifted.
- Follow manufacturer’s instructions for use of lifting equipment.
- Wear hard hat, safety shoes, and heavy gloves.

Failure to follow these instructions will result in death or serious injury.

Procedure Definition

Procedure characteristics	Description
Action	<ul style="list-style-type: none"> • Check the opening and closing of the safety shutters manually. • Check the locking and unlocking of the safety shutters with the optional VIVC locking accessory (MasterPacT MTZ2/MTZ3).
Goal	Verify that the safety shutters operate correctly and prevent access to the power circuit when the device is removed from the chassis.
Frequency	Refer to Recommended Frequency for the Intermediate End-User Maintenance Program, page 14.
Special indications	–

Procedure characteristics	Description
Necessary tools	<ul style="list-style-type: none"> • Padlock with shackle diameter 5–8 mm • Racking handle
Related documents, page 6	<ul style="list-style-type: none"> • <i>MasterPacT MTZ1 IEC Circuit Breakers with MicroLogic Active Control Unit - User Guide</i> • <i>MasterPacT MTZ2/MTZ3 IEC Circuit Breakers with MicroLogic Active Control Unit - User Guide</i> • <i>MasterPacT MTZ1 - Safety Shutters - Instruction Sheet</i> • <i>MasterPacT MTZ2/MTZ3 - Safety Shutters - Instruction Sheet</i> • <i>MasterPacT MTZ2/MTZ3 - VIVC Front Face Shutter Position Indication and Locking - Instruction Sheet</i>

Preliminary Conditions

The device must comply with the conditions specified below. Refer to the *MasterPacT MTZ User Guides* to find instructions for operating the device.

Device installation type	Position of poles	Mechanism	Device position in the chassis
Fixed	N/A	N/A	N/A
Drawout	Open	Discharged	Removed from chassis

Checking Safety Shutter Operation for MasterPacT MTZ1, MTZ2, and for MTZ3 Before 09/2022

Execute the following procedure for each safety shutter.

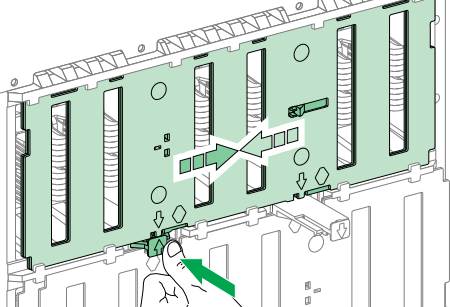
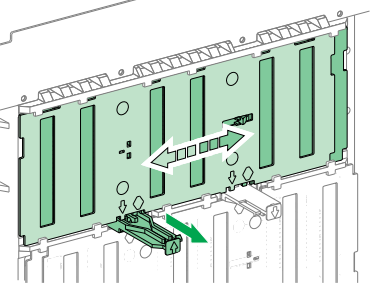
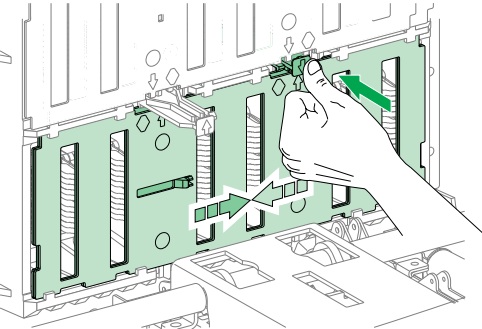
Step	Action	Corrective action
1	<p>Press and hold the opening mechanism of the top safety shutter until the shutter opens completely.</p> 	
2	<p>Quickly release the mechanism. The top shutter must close completely.</p> 	<p>If the shutter remains partially or completely open:</p> <ul style="list-style-type: none"> • Remove the shutter (refer to the relevant <i>MasterPacT MTZ - Safety Shutters - Instruction Sheet</i>). • Remove the shutter actuator (MasterPacT MTZ2). • Clean the shutter actuator and safety shutter to remove any grease or dust. • Reinstall the shutter actuator (MasterPacT MTZ2). • Reinstall the shutter. • Do the procedure again. <p>If the problem persists, replace:</p> <ul style="list-style-type: none"> • The safety shutter. • The shutter actuator (MasterPacT MTZ2). <p>Refer to the <i>MasterPacT MTZ Catalog</i> for spare parts.</p>
3	<p>Press and hold the opening mechanism of the bottom safety shutter until the shutter opens completely.</p> 	

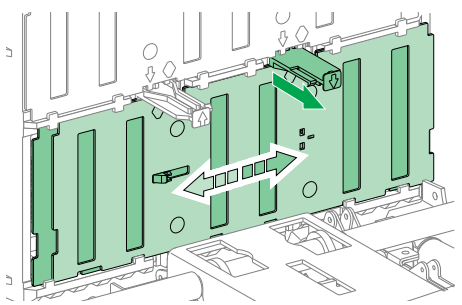
Step	Action	Corrective action
4	<p>Quickly release the mechanism.</p> <p>The bottom shutter must close completely.</p> 	<p>If the shutter remains partially or completely open, follow the corrective action described in step 2.</p>
5	<p>Repeat steps 1 to 4 of the procedure with a slow release of the mechanism until it has returned to its initial position. The slow release simulates the slow translation of the device during disconnection.</p> <p>Each shutter must close completely.</p>	<p>If a shutter remains partially or completely open, follow the corrective action described in step 2.</p>

Checking Safety Shutter Operation for MasterPacT MTZ3 After 09/2022

From 09/2022, each MTZ3 safety shutter protects the top and bottom chassis clusters of one phase. Prior to this date, one safety shutter protected the top chassis clusters of all phases, and one safety shutter protected the bottom chassis clusters of all phases.

Execute the following procedure for the safety shutter mechanism of each phase.

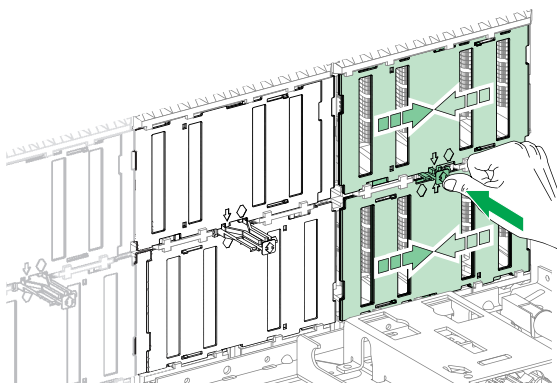
Step	Action	Corrective action
1	<p>Press and hold the opening mechanism of the safety shutters of one phase until the top and bottom shutters open completely.</p> 	
2	<p>Quickly release the mechanism.</p> <p>The top and bottom shutters must close completely.</p>	<p>If a shutter remains partially or completely open:</p> <ul style="list-style-type: none"> Remove the shutter (refer to the relevant <i>MasterPacT MTZ - Safety Shutters - Instruction Sheet</i>). Remove the shutter actuator. Clean the shutter actuator and safety shutter to remove any grease or dust. Reinstall the shutter actuator. Reinstall the shutter. Do the procedure again. <p>If the problem persists, replace:</p> <ul style="list-style-type: none"> The safety shutter. The shutter actuator. <p>Refer to the <i>MasterPacT MTZ Catalog</i> for spare parts.</p>

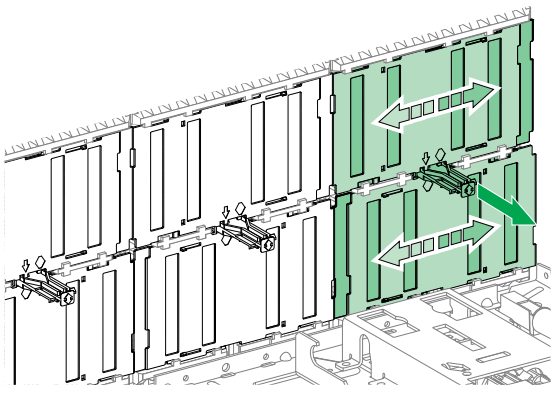
Step	Action	Corrective action
		
3	Press and hold the same opening mechanism again until the safety shutters open completely.	
4	Slowly release pressure until the mechanism has returned to initial position. The slow release simulates the slow translation of the device during disconnection. The top and bottom shutters must close completely.	If a shutter remains partially or completely open, follow the corrective action described in step 2.
5	Repeat the procedure for the shutter mechanism of each phase.	

Checking Shutter Padlocking with the VIVC Locking Accessory for MasterPacT MTZ2, and for MTZ3 Before 09/2022

Before starting this check, verify that the VIVC front face shutter position indication and locking accessory is mounted.

The top or bottom safety shutters can be locked individually or together on MasterPacT MTZ2 devices and on MasterPacT MTZ3 devices manufactured before 09/2022.

Safety shutter locking is only possible with the chassis in test or disconnected position.

Step	Action	Corrective action
1	Pull out the right-hand tab.	<p>If the tab cannot be pulled out, check that the locking accessory is correctly installed (refer to <i>MasterPacT MTZ2/MTZ3 - VIVC Front Face Shutter Position Indication and Locking - Instruction Sheet</i>).</p> <p>If the locking accessory is damaged, replace it.</p> <p>Refer to the <i>MasterPacT MTZ Catalog</i> for spare parts.</p> <p>If the problem persists, contact your Schneider Electric Services representative.</p>
2	Insert the padlock in this tab.	
3	Check that it is not possible to press the shutter actuator of the bottom safety shutter. The bottom safety shutter must remain closed.	<p>If the shutter actuator can be pressed and/or the safety shutter can be opened, remove and replace the shutter.</p> <p>If the problem persists, contact your Schneider Electric Services representative.</p>

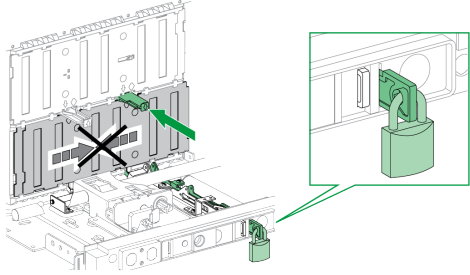
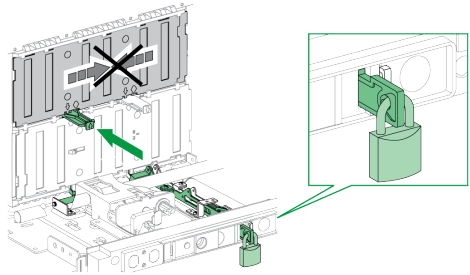
Step	Action	Corrective action
		
4	Check that the racking handle cannot be inserted.	If the racking handle can be inserted, contact your Schneider Electric Services representative
5	Remove the padlock.	
6	Pull out the left-hand tab.	
7	Insert the padlock in this tab.	
8	<p>Check that it is not possible to press the shutter actuator of the top safety shutter. The top safety shutter must remain closed.</p> 	<p>If the shutter actuator can be pressed and/or the safety shutter can be opened, remove and replace the shutter.</p> <p>If the problem persists, contact your Schneider Electric Services representative.</p>
9	Check that the racking handle cannot be inserted.	If the racking handle can be inserted, contact your Schneider Electric Services representative
10	Remove the padlock.	

Checking Shutter Padlocking with the VIVC Locking Accessory for MasterPacT MTZ3 After 09/2022

Before starting this check, verify that the VIVC front face shutter position indication and locking accessory is mounted.

The VIVC locking accessory locks all safety shutters together on MasterPacT MTZ3 devices manufactured after 09/2022.

Safety shutter locking is only possible with the chassis in test or disconnected position.

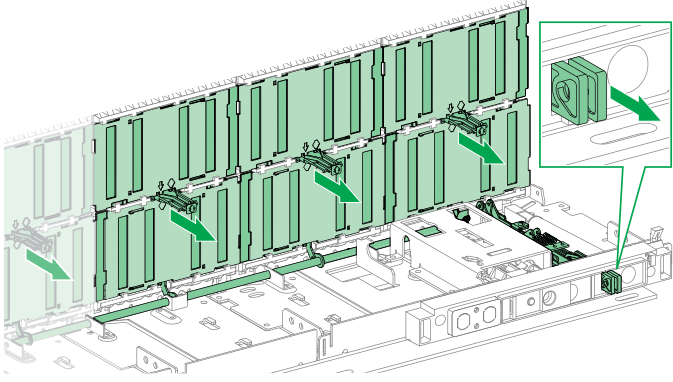
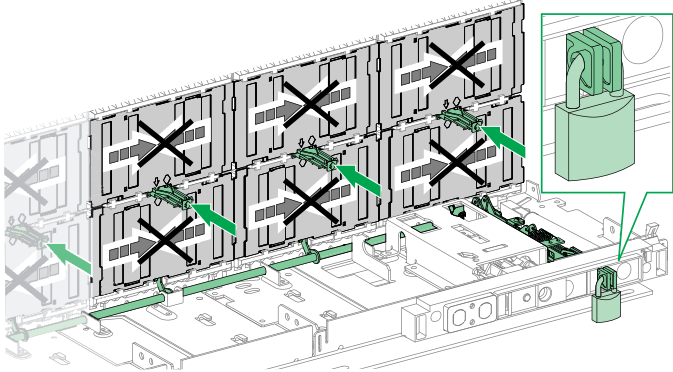
Step	Action	Corrective action
1	<p>Pull out the tabs.</p> 	<p>If the tab cannot be pulled out, check that the locking accessory is correctly installed (refer to <i>MasterPacT MTZ2/MTZ3 - VIVC Front Face Shutter Position Indication and Locking - Instruction Sheet</i>).</p> <p>If the locking accessory is damaged, replace it.</p> <p>Refer to the <i>MasterPacT MTZ Catalog</i> for spare parts.</p> <p>If the problem persists, contact your Schneider Electric Services representative.</p>
2	<p>Insert the padlock in the tabs.</p>	
3	<p>Check that it is not possible to press the shutter actuators of the safety shutter. The safety shutters must remain closed.</p> 	<p>If a shutter actuator can be pressed and/or the safety shutters can be opened, remove and replace the shutter.</p> <p>If the problem persists, contact your Schneider Electric Services representative.</p>
4	<p>Check that the racking handle cannot be inserted.</p>	<p>If the racking handle can be inserted, contact your Schneider Electric Services representative</p>
5	<p>Remove the padlock.</p>	

Chassis NIII_ZA_3: Clean Chassis and Check Presence of Grease on Chassis

Safety Instructions

⚡⚠ DANGER

HAZARD OF ELECTRIC SHOCK, EXPLOSION, OR ARC FLASH

- Apply appropriate personal protective equipment (PPE) and follow safe electrical work practices. See NFPA 70E, CSA Z462, NOM 029-STPS, or local equivalent.
- This equipment must only be installed and serviced by qualified electrical personnel.
- Unless specified otherwise in the maintenance procedures, all operations (inspection, test, and preventive maintenance) must be carried out with the device, the chassis, and the auxiliary circuits de-energized.
- Check that the device and the chassis are de-energized on the upstream and downstream terminals.
- Always use a properly rated voltage sensing device to confirm that the device, the chassis, and the auxiliary circuits are de-energized.
- Install safety barriers and display a danger sign.
- During the tests, it is strictly forbidden for anyone to touch the device, the chassis, or the conductors while voltage is applied.
- Before turning on power to this equipment, check that all connections are made with the correct tightening torque and the device is off (open position).
- Before turning on power to this equipment, put all devices, doors, and covers back in place.
- Before turning on power to this equipment, beware of potential hazards and carefully inspect the work area for tools and objects that may have been left inside the equipment.

Failure to follow these instructions will result in death or serious injury.

⚠ DANGER

HAZARD OF DEVICE FALLING

- Be sure that lifting equipment has lifting capacity for the device being lifted.
- Follow manufacturer’s instructions for use of lifting equipment.
- Wear hard hat, safety shoes, and heavy gloves.

Failure to follow these instructions will result in death or serious injury.

Procedure Definition

Procedure characteristics	Description
Action	<ul style="list-style-type: none"> • Check cleanliness of internal parts of the chassis (no dust) and presence of grease. • If necessary, spread the grease uniformly across the mechanical parts of the chassis.
Goal	Verify the smooth mechanical racking-in and racking-out of the device.
Frequency	Refer to Recommended Frequency for the Intermediate End-User Maintenance Program, page 15.
Special indications	–

Procedure characteristics	Description
Necessary tools	<ul style="list-style-type: none"> Vacuum cleaner Small paintbrush
Related documents, page 6	<ul style="list-style-type: none"> <i>MasterPacT MTZ1 IEC Circuit Breakers with MicroLogic Active Control Unit - User Guide</i> <i>MasterPacT MTZ2/MTZ3 IEC Circuit Breakers with MicroLogic Active Control Unit - User Guide</i>

Preliminary Conditions

The device must comply with the conditions specified below. Refer to the *MasterPacT MTZ User Guides* to find instructions for operating the device.

Device installation type	Position of poles	Mechanism	Device position in the chassis
Fixed	N/A	N/A	N/A
Drawout	Open	Discharged	Removed from chassis

Checking Cleanliness of Internal Parts of Chassis

 **DANGER**

HAZARD OF ELECTRIC SHOCK, EXPLOSION, OR ARC FLASH

- The chassis must be de-energized on the upstream and downstream terminals.
- Always use a properly rated voltage sensing device to confirm that the chassis and the auxiliary circuits are de-energized.

Failure to follow these instructions will result in death or serious injury.

Check cleanliness of the internal parts of the chassis. In presence of dust, use a vacuum cleaner to remove it.

NOTICE

HAZARD OF EQUIPMENT DAMAGE

Do not use pressurized cleaning products or products containing solvents (trichloroethane or trichloroethylene) such as WD40.

Failure to follow these instructions can result in equipment damage.

Checking Greasing of Internal Parts of Chassis

Step	Action	Corrective action
1	<p>Check the color and texture of grease. See parts indicated in the corresponding illustrations for MasterPacT MTZ1, page 144 or MasterPacT MTZ2/MTZ3, page 145.</p> <p>NOTE:</p> <ul style="list-style-type: none"> Dust mixed with grease can be abrasive and can lead to premature wear of mechanisms. Dust mixed with grease can increase mechanical friction and blocking moving parts. 	<p>If there is a change in grease (for example, grease is dirty or hardened on the mechanical parts of the chassis), contact your Schneider Electric Services representative.</p>
2	<p>Check if the grease on the mechanical parts is applied uniformly on the whole zone concerned. See parts indicated in the corresponding illustrations for MasterPacT MTZ1, page 144 or MasterPacT MTZ2/MTZ3, page 145.</p> <p>NOTE:</p> <ul style="list-style-type: none"> Too much grease impacts negatively on the device operation. Absence of grease increases racking forces and leads to blocking moving parts. 	<ul style="list-style-type: none"> If there is excessive grease, spread the grease uniformly across the zone with a small paintbrush. If there is no grease, contact your Schneider Electric Services representative.

Grease Points On MasterPacT MTZ1 Chassis

Check grease points on the right and left hand-side of the chassis as indicated on the zones identified in these illustrations.

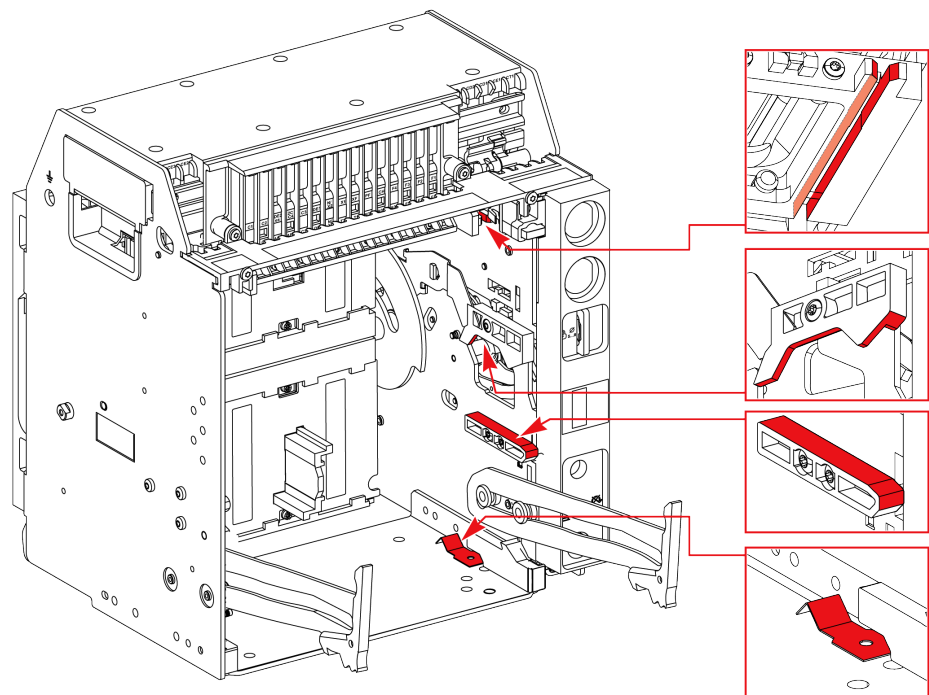

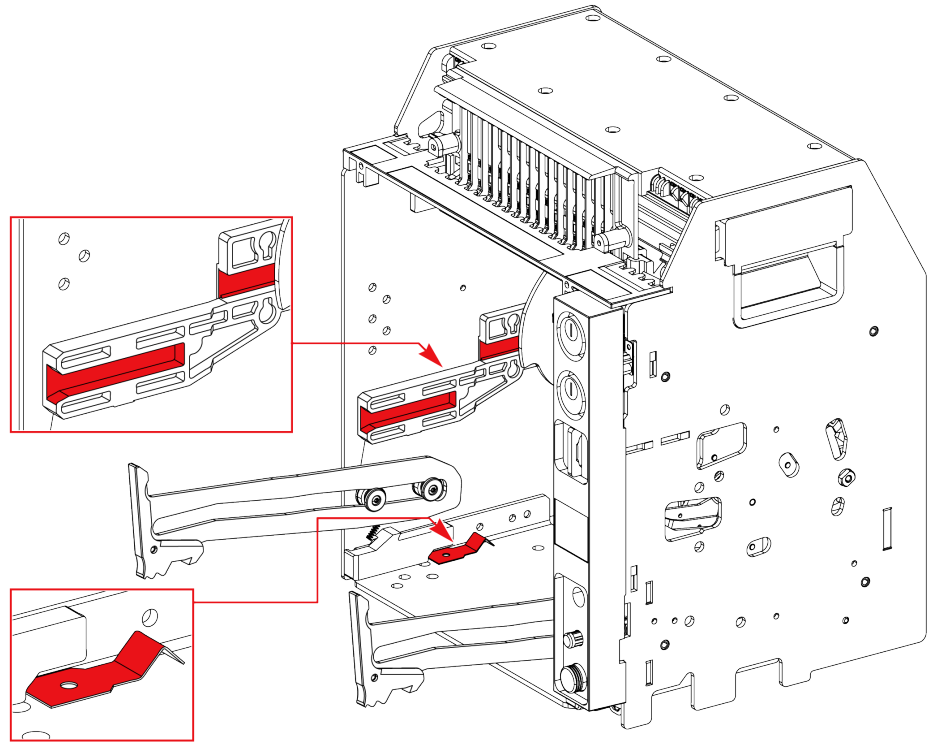

Grease Points On MasterPacT MTZ2/MTZ3 Chassis

Check grease points symmetrically on the right and left hand-side of the chassis as indicated on the zones identified in these illustrations.

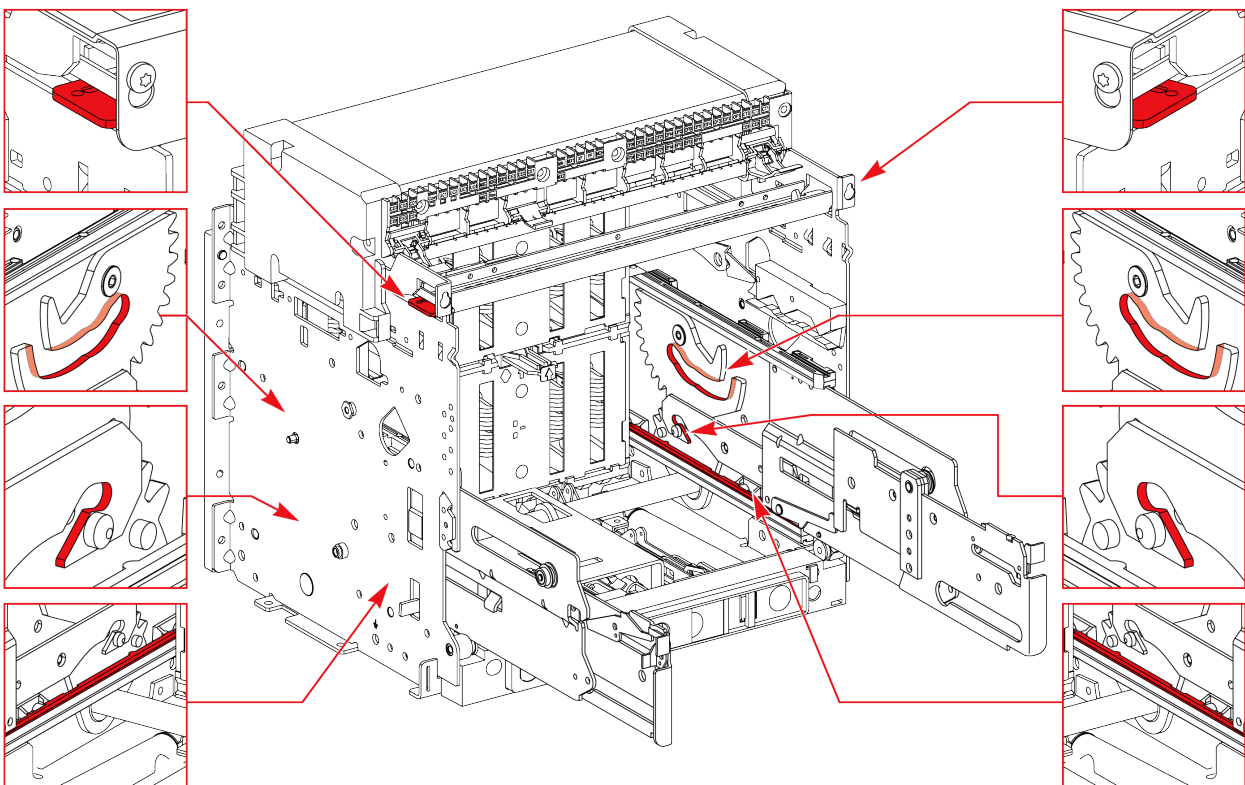

Chassis NIII_ZA_4: Check Disconnecting Contact Clusters

Safety Instructions

⚡⚠ DANGER

HAZARD OF ELECTRIC SHOCK, EXPLOSION, OR ARC FLASH

- Apply appropriate personal protective equipment (PPE) and follow safe electrical work practices. See NFPA 70E, CSA Z462, NOM 029-STPS, or local equivalent.
- This equipment must only be installed and serviced by qualified electrical personnel.
- Unless specified otherwise in the maintenance procedures, all operations (inspection, test, and preventive maintenance) must be carried out with the device, the chassis, and the auxiliary circuits de-energized.
- Check that the device and the chassis are de-energized on the upstream and downstream terminals.
- Always use a properly rated voltage sensing device to confirm that the device, the chassis, and the auxiliary circuits are de-energized.
- Install safety barriers and display a danger sign.
- During the tests, it is strictly forbidden for anyone to touch the device, the chassis, or the conductors while voltage is applied.
- Before turning on power to this equipment, check that all connections are made with the correct tightening torque and the device is off (open position).
- Before turning on power to this equipment, put all devices, doors, and covers back in place.
- Before turning on power to this equipment, beware of potential hazards and carefully inspect the work area for tools and objects that may have been left inside the equipment.

Failure to follow these instructions will result in death or serious injury.

⚠ DANGER

HAZARD OF DEVICE FALLING

- Be sure that lifting equipment has lifting capacity for the device being lifted.
- Follow manufacturer’s instructions for use of lifting equipment.
- Wear hard hat, safety shoes, and heavy gloves.

Failure to follow these instructions will result in death or serious injury.

Procedure Definition

Procedure characteristics	Description
Action	Visually check the disconnecting contact clusters and cluster supports.
Goal	<ul style="list-style-type: none"> • Verify the smooth mechanical racking-in of the device. • Verify the smooth racking-out of the device (avoid pulling out the clusters during disconnection).
Frequency	Refer to Recommended Frequency for the Intermediate End-User Maintenance Program, page 15.
Special indications	–

Procedure characteristics	Description
Necessary tools	–
Related documents, page 6	<ul style="list-style-type: none"> • <i>MasterPacT MTZ1 IEC Circuit Breakers with MicroLogic Active Control Unit - User Guide</i> • <i>MasterPacT MTZ2/MTZ3 IEC Circuit Breakers with MicroLogic Active Control Unit - User Guide</i>

Preliminary Conditions

The device must comply with the conditions specified below. Refer to the *MasterPacT MTZ User Guides* to find instructions for operating the device.

Device installation type	Position of poles	Mechanism	Device position in the chassis
Fixed	N/A	N/A	N/A
Drawout	Open	Discharged	Removed from chassis

Checking Disconnecting Contact Clusters

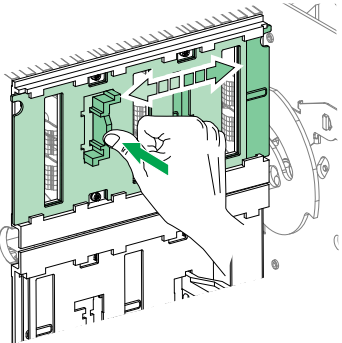
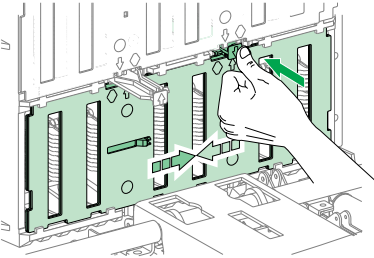
Step	Action	Corrective action
1	If present, remove the VIVC locking accessory for safety shutters (MasterPacT MTZ2/MTZ3).	
2	<p>Without removing the safety shutters, visually check the disconnecting contact clusters.</p> <ul style="list-style-type: none"> • MasterPacT MTZ1  <ul style="list-style-type: none"> • MasterPacT MTZ2 and MasterPacT MTZ2/MTZ3 (before 08/2022) 	

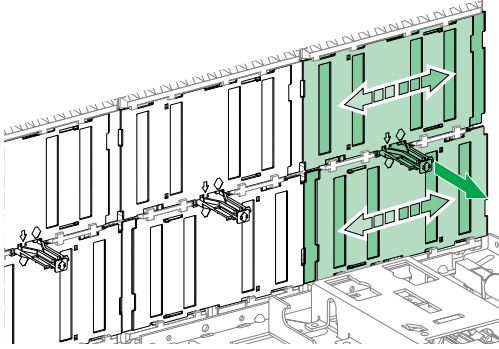
Step	Action	Corrective action
	<ul style="list-style-type: none"> MasterPacT MTZ2/MTZ3 (after 08/2022) 	
3	Check that no copper is present on the surface of the clusters.	If copper is visible, contact your Schneider Electric Services representative.
4	Check if the disconnecting contact clusters are blackened.	If the disconnecting contact clusters are blackened, contact your Schneider Electric Services representative.
5	Check the state of the grease on disconnecting contact clusters.	If there is no grease or there is a change in color or texture of grease, contact your Schneider Electric Services representative.
6	Reinstall the optional VIVC locking accessory for safety shutters (MasterPacT MTZ2/MTZ3).	

Power Connections NIII_ZA_1: Check Connection System

Safety Instructions

⚠️⚠️ DANGER

HAZARD OF ELECTRIC SHOCK, EXPLOSION, OR ARC FLASH

- Apply appropriate personal protective equipment (PPE) and follow safe electrical work practices. See NFPA 70E, CSA Z462, NOM 029-STPS, or local equivalent.
- This equipment must only be installed and serviced by qualified electrical personnel.
- Unless specified otherwise in the maintenance procedures, all operations (inspection, test, and preventive maintenance) must be carried out with the device, the chassis, and the auxiliary circuits de-energized.
- Check that the device and the chassis are de-energized on the upstream and downstream terminals.
- Always use a properly rated voltage sensing device to confirm that the device, the chassis, and the auxiliary circuits are de-energized.
- Install safety barriers and display a danger sign.
- During the tests, it is strictly forbidden for anyone to touch the device, the chassis, or the conductors while voltage is applied.
- Before turning on power to this equipment, check that all connections are made with the correct tightening torque and the device is off (open position).
- Before turning on power to this equipment, put all devices, doors, and covers back in place.
- Before turning on power to this equipment, beware of potential hazards and carefully inspect the work area for tools and objects that may have been left inside the equipment.

Failure to follow these instructions will result in death or serious injury.

⚠️ DANGER

HAZARD OF DEVICE FALLING

- Be sure that lifting equipment has lifting capacity for the device being lifted.
- Follow manufacturer’s instructions for use of lifting equipment.
- Wear hard hat, safety shoes, and heavy gloves.

Failure to follow these instructions will result in death or serious injury.

Procedure Definition

Procedure characteristics	Description
Action	<ul style="list-style-type: none"> • Check that the connection terminals and cables and/or busbars are correctly tightened. • Check presence and state of grease. • Check penetration of terminals in clusters in the case of a drawout device. • Clean contact surfaces.
Goal	Verify normal temperature rise on device and customer connections according to IEC standards.
Frequency	Refer to Recommended Frequency for the Intermediate End-User Maintenance Program, page 15.

Procedure characteristics	Description
Special indications	–
Necessary tools	<ul style="list-style-type: none"> • White abrasive pad (for example, Scotch-Brite) • Torque wrench • Small paintbrush • New bolts, nuts, and washers
Related documents, page 6	<ul style="list-style-type: none"> • <i>MasterPacT MTZ1 IEC Circuit Breakers with MicroLogic Active Control Unit - User Guide</i> • <i>MasterPacT MTZ2/MTZ3 IEC Circuit Breakers with MicroLogic Active Control Unit - User Guide</i> • <i>MasterPacT MTZ1 - Connectors - Instruction Sheet</i> • <i>MasterPacT MTZ2/MTZ3 - Connectors - Instruction Sheet</i>

Preliminary Conditions

The device must comply with the conditions specified below. Refer to the *MasterPacT MTZ User Guides* to find instructions for operating the device.

Device installation type	Position of poles	Mechanism	Device position in the chassis
Fixed	–	–	N/A
Drawout	–	–	Removed from chassis

Example of Hardware Connection

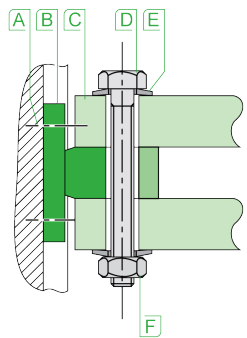

A Terminal screw factory-tightened to 13 N•m (MasterPacT MTZ1) and 17 N•m (MasterPacT MTZ2/MTZ3)

B Circuit breaker terminal



C Busbar

D Bolt

E Washer

F Nut

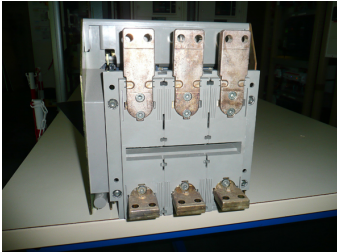
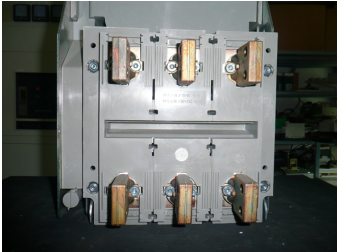
Fixed Device: Checking Mounting of Connection Terminals to Device and Cables And/Or Busbars to Connection Terminals

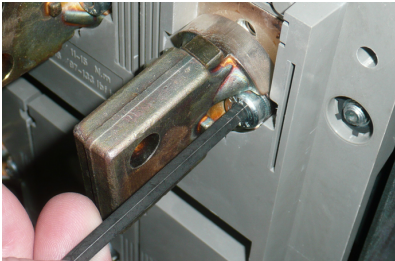
Step	Action	Corrective action
1	<p>Disconnect busbars from all the connection terminals.</p> <p>Connection types:</p> <ul style="list-style-type: none"> • Mixed connection  <ul style="list-style-type: none"> • Vertical rear connection  <ul style="list-style-type: none"> • Horizontal rear connection 	<p>Advise customer in case of damage to busbars noticed during disconnection.</p>
2	<p>Check the recommended torque value on the device:</p> <ul style="list-style-type: none"> • For MasterPacT MTZ1: 13 N•m  <ul style="list-style-type: none"> • For MasterPacT MTZ2/MTZ3: 17 N•m 	
3	<p>Make sure that the screws are not overtightened:</p> <ol style="list-style-type: none"> 1. Set the torque wrench to 1 N•m under the recommended value, and then tighten connection terminals to this value. 	<p>If a screw cannot be tightened to this value, contact your Schneider Electric Services representative.</p>

Step	Action	Corrective action
	2. Set the torque wrench to the recommended value, and then tighten connection terminals to this value.	
4	Clean the busbar contact surfaces and customer terminals by using a white abrasive pad.	If there is a major change in color, contact your Schneider Electric Services representative.
5	Disconnect cables from all the connection terminals.	Advise customer in case of damage to cables noticed during disconnection.
6	Clean the contact surfaces of the cable lugs by using a white abrasive pad.	Advise customer in case of damage to the cable insulation (for example, cracks or cable shrinkage).
7	Reconnect the cables and/or busbars with a new set of bolts, nuts, and washers, and then tighten to the recommended torque. NOTE: Standard connection hardware is class 8.8 steel hardware with contact washers. For MTZ2 40, MTZ3 40, MTZ3 50, and MTZ3 63, it is recommended to use A80 stainless steel hardware.	

Drawout Device: Checking Mounting of Connection Terminals to Device and Cables And/Or Busbars to Connection Terminals

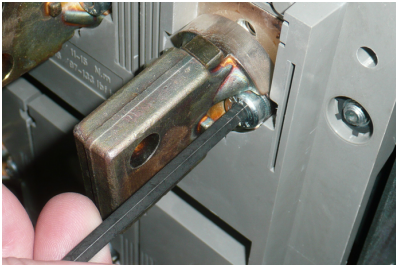
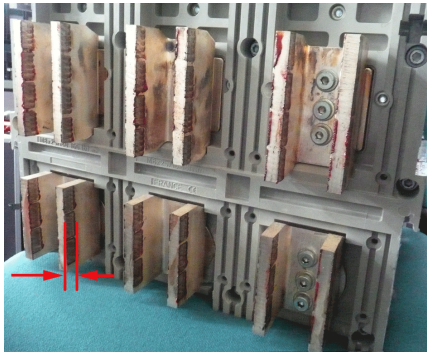
Step	Action	Corrective action
1	Check the recommended torque value on the device: <ul style="list-style-type: none"> • For MasterPacT MTZ1: 13 N•m • For MasterPacT MTZ2/MTZ3: 17 N•m 	
2	Make sure that the screws are not overtightened: <ol style="list-style-type: none"> 1. Set the torque wrench to 1 N•m under the recommended value, and then tighten connection terminals to this value.  <ol style="list-style-type: none"> 2. Set the torque wrench to the recommended value, and then tighten connection terminals to this value. 	If a screw cannot be tightened to this value, contact your Schneider Electric Services representative.
3	Check the state of the grease on internal terminals on device.	<ul style="list-style-type: none"> • If there is excessive grease, spread the grease uniformly across the zone with a small paintbrush. • If there is no grease or there is a change in color or texture of grease, contact your Schneider Electric Services representative.
4	Check that the depth of the penetration of internal terminals in the clusters, indicated by the mark, is about 5 mm. 	If penetration depth is less than 5 mm, contact your Schneider Electric Services representative.

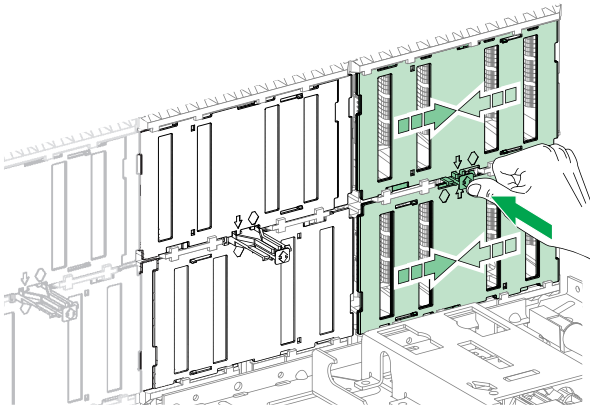
Step	Action	Corrective action
5	Open manually the top and bottom safety shutters, and check presence of grease on the clusters. 	<ul style="list-style-type: none"> • If there is excessive grease, spread the grease uniformly across the zone with a small paintbrush. • If there is no grease or there is a change in color or texture of grease, contact your Schneider Electric Services representative.
6	Disconnect customer cables and/or busbars from all the connection terminals on the chassis.	Advise customer in case of damage to cables or busbars noticed during disconnection.
7	Make sure that the screws are not overtightened: Set the torque wrench to 1 N•m under the recommended value, and then tighten connection terminals to this value.	If a screw cannot be tightened to this value, contact your Schneider Electric Services representative.
8	Without removing the customer terminals, tighten connection terminals to the recommended value: <ul style="list-style-type: none"> • For MasterPacT MTZ1: 13 N•m • For MasterPacT MTZ2/MTZ3: 17 N•m 	If a screw cannot be tightened to this value, contact your Schneider Electric Services representative.
9	Clean the busbar contact surfaces and customer terminals by using a white abrasive pad.	If there is a major change in color, contact your Schneider Electric Services representative.
10	Clean the contact surfaces of the cable lugs by using a white abrasive pad.	
11	Reconnect the cables and/or busbars with a new set of bolts, nuts, and washers, and then tighten to the recommended torque. NOTE: Standard connection hardware is class 8.8 steel hardware with contact washers. For MTZ2 40, MTZ3 40, MTZ3 50, and MTZ3 63, it is recommended to use A80 stainless steel hardware.	

Terminal Mounting on Device and Recommended Tightening Torque

Refer to the following documentation:

- *MasterPacT MTZ1 - Connectors - Instruction Sheet*
- *MasterPacT MTZ2/MTZ3 - Connectors - Instruction Sheet*

Recommended Tightening Torque of Connecting Busbars

The following table shows the tightening torques to be used for connecting busbars (Cu ETP - French standard NFA 51-100) to the circuit breaker. These values are for use with copper busbars and steel nuts and bolts, class 8.8. The same torques can be used with AGS-T52 quality aluminum bars (French standard NFA 02-104 or American National Standard H-35-1).

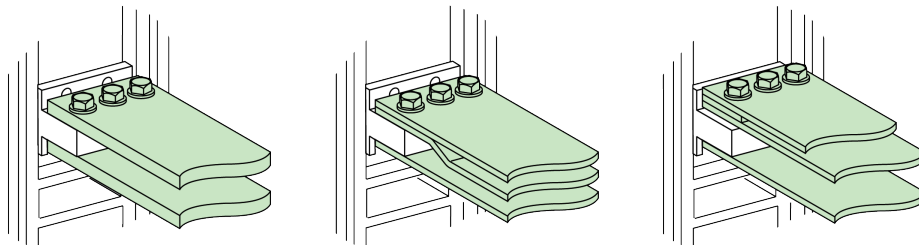

Ø (mm) Nominal	Ø (mm) Drilling	Tightening torques (N•m) with grower or flat washers	Tightening torques (N•m) with contact or corrugated washers
10	11	37.5	50

MasterPacT MTZ Troubleshooting

What's in This Part

Introduction to Troubleshooting	156
Troubleshooting: Chassis Operation	158
Troubleshooting: Unexpected Tripping	159
Troubleshooting: Mechanical Control Operations	160
Troubleshooting: Electrical Control Operations	162

Introduction to Troubleshooting

Presentation

This part contains information for troubleshooting problems in a working system. It assumes that the system is correctly installed and that all the commissioning tests have been completed successfully. The troubleshooting operations are described under the following headings:

- Chassis operation
- Unexpected tripping
- Mechanical control operations
- Electrical control operations

Layer Model

When troubleshooting the device, it is useful to consider a layer model. There are three layers:

- Direct connection
- Electrical
- Mechanical

The following diagram shows the layers in the device:

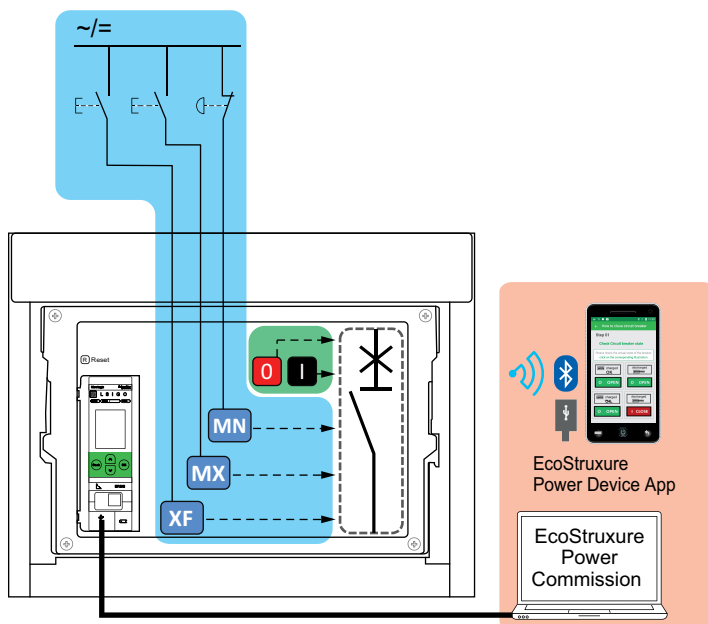

- Direct communication
- Electrical
- Mechanical

If the troubleshooting actions for a layer are not successful, go to the next layer until you reach the Mechanical layer. If you cannot solve the problem after troubleshooting the Mechanical layer, contact your Schneider Electric Services representative.

Maintenance of the Device

Schneider Electric recommends a preventive maintenance program to ensure that devices retain the operating and technical characteristics specified in the catalogs during their service life. Maintenance must be carried out by trained and qualified personnel.

For information about the preventive maintenance program and maintenance procedures, refer to DOCA0305• *MasterPacT MTZ IEC Circuit Breakers with MicroLogic Active Control Unit - Maintenance Guide* in **Related Documents** at the beginning of this guide.

Troubleshooting: Chassis Operation

Definition

Chassis operation includes the following:

- Racking in and racking out the drawout circuit breaker
- Locking and unlocking the chassis

Troubleshooting

Problem description	Probable causes	Solutions
Impossible to insert the racking handle in connected, test, or disconnected position.	A padlock or keylock is present on the chassis or a door interlock is present.	Disable the locking function.
Impossible to turn the racking handle.	The position release button is not pushed in and so the racking handle cannot be rotated.	Push the position release button.
Circuit breaker cannot be removed from chassis.	Circuit breaker is not in the disconnected position.	Turn the racking handle until the circuit breaker is in the disconnected position and the position release button pops out.
	Rails are not completely extended.	Pull out the rails of the chassis.
Circuit breaker cannot be connected (racked in).	Chassis and circuit breaker do not match (mismatch protection).	Check that the chassis corresponds with the circuit breaker.
	Safety shutters are locked.	Remove the locks.
	Disconnecting contact clusters are incorrectly positioned.	Reposition the disconnecting contact clusters.
	Chassis is locked in the disconnected position.	Disable the chassis locking function.
	The position release button is not pushed in and so the racking handle cannot be rotated.	Push the position release button.
Circuit breaker cannot be locked in the disconnected position.	Circuit breaker has not been sufficiently inserted in the chassis.	Insert the circuit breaker completely so that it is engaged in the racking mechanism.
	Circuit breaker is not in the correct position.	Check the circuit breaker position by checking that the position release button is popped out.
Circuit breaker cannot be locked in the connected, test, or disconnected position.	Racking handle is still in the chassis.	Remove the racking handle and store it.
	Locking in any position is not enabled.	Adapt the chassis locking mechanism so that the chassis can be locked in any position.
	Circuit breaker is not in the correct position.	Check the circuit breaker position by checking that the position release button is out.
The racking handle cannot be inserted to connect or disconnected the circuit breaker.	Racking handle is still in the chassis.	Remove the racking handle and store it.
	Rails are not completely in.	Push the rails all the way in.
The right-hand rail (chassis alone) or the circuit breaker cannot be drawn out.	Racking handle is still in the chassis.	Remove the racking handle and store it.

Troubleshooting: Unexpected Tripping

Definition

Unexpected tripping is tripping that is not caused by a protection function during normal operation or by tests.

Troubleshooting



Problem description	Symptom	Probable causes	Solutions
Circuit breaker opened without any over-current electrical fault.	The blue fault-trip reset button is not popped out and no trip cause LED is lit.	Drop in voltage to below the threshold detected by MN undervoltage release.	Check the voltage and the MN supply circuit ($V > 0.85 U_n$).
		An order (for example load-shedding) sent to the MX opening voltage release by another circuit breaker.	Check the parameters of the circuit breaker that sent the order.
		Unnecessary opening order from the MX opening voltage release.	Determine the origin of the order and cancel it.
Circuit breaker trips in a shorter time than expected after attempt to close the circuit breaker.	The blue fault-trip reset button is popped out and the L trip cause LED is blinking red.	Thermal memory is still active and current on the line is above the I_r threshold.	Check whether there is still an overload on the line. If necessary, make a correction. For details of thermal memory, refer to DOCA0265•• <i>MasterPacT MTZ - MicroLogic Active Control Unit - User Guide</i> in Related Documents at the beginning of this guide.
	The blue fault-trip reset button is popped out, the I trip cause LED is lit, and the ERMS LED is lit.	ERMS is active so circuit breaker opens at lower protection settings.	The ERMS function applies reduced protection settings for use during maintenance. Check whether maintenance is in progress. If ERMS is no longer necessary, disengage it to revert to normal protection settings.
Immediate tripping after an attempt to close the circuit breaker.	The blue fault-trip reset button is popped out and the L trip cause LED is blinking red.	Transient overcurrent when closing.	<ul style="list-style-type: none"> • Modify the distribution system or the control unit settings. • Check the condition of the circuit breaker before putting it back into service.
Immediate tripping after an attempt to close the circuit breaker with activation of the blue fault-trip reset button.	–	Closing on a short-circuit.	Refer to MasterPacT MTZ critical cases.
Nuisance tripping of the circuit breaker with activation of the blue fault-trip reset button.	–	Blue fault-trip reset button is not pushed-in completely.	Push in the blue fault-trip reset button completely.
	–	Transient overcurrent detected on the line and fast instantaneous trip setting is active in EcoStruxure Power Commission software.	Intended behavior. If necessary, adjust the settings in EcoStruxure Power Commission software.

Troubleshooting: Mechanical Control Operations

Definition

Mechanical control operations are operations that are made using the opening or closing pushbuttons.

Circuit Breaker Cannot be Closed by Using the Mechanical Closing Pushbutton

Symptom	Probable causes	Solutions
The blue fault-trip reset button is popped out.	The blue fault-trip reset button has not been reset.	<ul style="list-style-type: none"> Clear the fault. Push the blue fault-trip reset button.
–	Circuit breaker is padlocked or keylocked in the open position.	Unlock the circuit breaker.
–	Circuit breaker is interlocked mechanically in a mechanical interlocking system.	<ul style="list-style-type: none"> Check the position of the other circuit breaker in the changeover system. Modify the situation to release the interlock.
The closing spring and ready-to-close indicator shows that the mechanism is discharged. 	Stored energy mechanism is not charged.	<ul style="list-style-type: none"> Charge the mechanism manually. If the circuit breaker is equipped with an MCH gear motor, check the supply of power to the motor. If the problem persists, replace the MCH gear motor.
The closing spring and ready-to-close indicator shows that the mechanism is charged but the circuit breaker is not ready to close. 	MX opening voltage release is permanently powered.	As there is an opening order, determine the origin of the order. The order must be canceled before the circuit breaker can be closed.
	MN undervoltage release is not powered due to an opening order.	As there is an opening order, determine the origin of the order. The order must be canceled before the circuit breaker can be closed.
	MN undervoltage release is not powered due to insufficient voltage power supply.	Check the voltage and the MN supply circuit ($V > 0.85 U_n$). If the problem persists, replace the MN undervoltage release.
Recurring undervoltage trip.	The measured voltage remains at 0 V.	Set the undervoltage behavior parameter, V_{min} behavior, to Force to Off when CB is open . For more information, refer to DOCA0265** <i>MasterPacT MTZ - MicroLogic Active Control Unit - User Guide</i> in Related Documents at the beginning of this guide.
The position release button on the chassis of the drawout circuit breaker is pushed in.	Circuit breaker is not correctly connected.	Terminate racking in (connection) of the circuit breaker, making sure that it is fully inserted in the chassis, to the connected position. Check that the position release button is popped out.

Circuit Breaker Cannot be Opened by Using the Mechanical Opening Pushbutton

Probable causes	Solutions
Operating mechanism incident or welded contacts.	Contact your Schneider Electric Services representative.

Troubleshooting: Electrical Control Operations

Definition

Electrical control operations are operations that are made by an electrical order through a voltage release or by an external pushbutton that is directly connected to a voltage release.

Circuit Breaker Cannot be Closed by Using an External Pushbutton/Electrical Order

Symptom	Probable causes	Solutions
–	Circuit breaker is padlocked or keylocked in the open position.	Unlock the circuit breaker.
–	Electrical closing order not executed by the XF closing voltage release due to insufficient voltage power supply.	Check the voltage and the XF supply circuit (0.85–1.1 Un). If the problem persists, replace the XF closing voltage release.
The closing spring and ready-to-close indicator shows that the mechanism is charged but the circuit breaker is not ready to close. 	MX opening voltage release is permanently powered.	As there is an opening order, determine the origin of the order. The order must be canceled before the circuit breaker can be closed.
	MN undervoltage release is not powered due to an opening order.	As there is an opening order, determine the origin of the order. The order must be canceled before the circuit breaker can be closed.
	MN undervoltage release is not powered due to insufficient voltage power supply.	Check the voltage and the MN supply circuit ($V > 0.85 U_n$). If the problem persists, replace the MN undervoltage release.
–	XF closing voltage release is continuously supplied, but circuit breaker was not ready-to-close when the closing order was sent (XF closing voltage release is not wired in series with PF ready-to-close contact).	<ul style="list-style-type: none"> Remove the power supply to the XF closing voltage release. Only if the circuit breaker is ready-to-close, send the closing order again via the XF closing voltage release.

Circuit Breaker Cannot be Opened by Using an External Pushbutton/Electrical Order

Probable causes	Solutions
Opening order is not executed by the MN undervoltage release.	Drop in voltage insufficient or residual voltage ($V > 0.35 U_n$) across the terminals of the MN undervoltage release. If the problem persists, replace the MN undervoltage release.
Opening order is not executed by the MX opening voltage release.	Check the voltage and the MX supply circuit (0.7–1.1 Un). If the problem persists, replace the MX opening voltage release.

Circuit Breaker Cannot be Reset by Using RES Electrical Remote Reset

Symptom	Probable causes	Solutions
The blue fault-trip reset button is popped out.	Insufficient supply voltage for the RES electrical remote reset.	Check the voltage and the RES supply circuit (0.7–1.1 Un). If the problem persists, replace the RES electrical remote reset.

Additional Checks

If the troubleshooting actions described above do not work, refer to the troubleshooting information for [Mechanical Control Operations](#), page 160.

Schneider Electric
35 rue Joseph Monier
92500 Rueil Malmaison
France

+ 33 (0) 1 41 29 70 00

www.se.com

As standards, specifications, and design change from time to time,
please ask for confirmation of the information given in this publication.

© 2024 Schneider Electric. All rights reserved.

DOCA0306EN-00